

# OBJECT-ORIENTED PROGRAMMING AND THE OBJECTIVE-C LANGUAGE

---

NeXT DEVELOPER'S LIBRARY



NeXT Software, Inc.  
900 Chesapeake Drive  
Redwood City, CA 94063  
U.S.A.

We at NeXT have tried to make the information contained in this publication as accurate and reliable as possible. Nevertheless, NeXT disclaims any warranty of any kind, whether express or implied, as to any matter whatsoever relating to this publication, including without limitation the merchantability or fitness for any particular purpose. NeXT will from time to time revise the software described in this publication and reserves the right to make such changes without the obligation to notify the purchaser. In no event shall NeXT be liable for any indirect, special, incidental, or consequential damages arising out of purchase or use of this publication or the information contained herein.

Restricted Rights Legend: Use, duplication, or disclosure by the Government is subject to restrictions as set forth in subparagraph (c)(1)(ii) of the Rights in Technical Data and Computer Software clause at DFARS 252.227-7013 (or, if applicable, similar clauses at FAR 52.227-19 or NASA FAR Supp. 52.227-86).

Copyright 1993-1995 NeXT Software, Inc. All Rights Reserved.  
[6123.01]

NeXT, the NeXT logo, NEXTSTEP, NetInfo, and Objective-C are registered trademarks of NeXT Software, Inc. The NEXTSTEP logo, Application Kit, Enterprise Object, Enterprise Objects Framework, Interface Builder, OPENSTEP, the OPENSTEP logo, PDO, Portable Distributed Objects, WebObjects, and Workspace Manager are trademarks of NeXT Software, Inc. Use in commerce other than as "fair use" is prohibited by law except by express license from NeXT Software, Inc.

PostScript is a registered trademark of Adobe Systems, Incorporated. Unix is a registered trademark of UNIX Systems Laboratories, Inc. All other trademarks mentioned belong to their respective owners.

U.S. and foreign patents are pending on NeXT products.  
NetInfo: U.S. Patent No. 5,410,691  
NEXTSTEP: U.S. Patent Nos. 5,184,124; 5,355,483; 5,388,201; 5,423,039; 5,432,937.  
Cryptography: U.S. Patent Nos. 5,159,632; 5,271,061.

Address inquiries concerning usage of NeXT trademarks, designs, or patents to General Counsel, NeXT Computer, Inc., 900 Chesapeake Drive, Redwood City, CA 94063 USA.)

Writing: Don Larkin and Greg Wilson  
Book design: Cindy Steinberg  
Illustration: Dan Marusich  
Production: Jennifer Sherer  
Publications management: Ron Hayden  
Cover design: CKS Partners, San Francisco, California

---

## TABLE OF CONTENTS

<b>1</b>	<b>Chapter: Introduction</b>	<b>63</b>	<b>Defining A Class</b>
4	The Development Environment		The Interface
5	Why Objective-C		The Implementation
6	How the Manual is Organized	<b>74</b>	<b>How Messaging Works</b>
7	Conventions		Selectors
			Hidden Arguments
			Messages to self and super
<b>9</b>	<b>Chapter: Object-Oriented Programming</b>	<b>89</b>	<b>Chapter: Objective-C Extensions</b>
11	Interface and Implementation	<b>91</b>	<b>Categories</b>
15	The Object Model		Adding to a Class
	The Messaging Metaphor		How Categories Are Used
	Classes		Categories of the Root Class
	Mechanisms Of Abstraction	<b>94</b>	<b>Protocols</b>
	Inheritance		How Protocols Are Used
	Dynamism		Informal Protocols
<b>33</b>	<b>Structuring Programs</b>		Formal Protocols
	Outlet Connections	<b>105</b>	<b>Remote Messaging</b>
	Aggregation and Decomposition		Distributed Objects
	Models and Frameworks		Language Support
<b>38</b>	<b>Structuring the Programming Task</b>	<b>113</b>	<b>Static Options</b>
	Collaboration		Static Typing
	Organizing Object-Oriented Projects		Getting a Method Address
			Getting an Object Data Structure
<b>43</b>	<b>Chapter: The Objective-C Language</b>	<b>119</b>	<b>Type Encoding</b>
45	Objects	<b>123</b>	<b>Chapter: The Run-Time System</b>
	id	<b>126</b>	<b>Allocation and Initialization</b>
	Dynamic Typing		Allocating Memory For Objects
47	Messages		Initializing New Objects
	The Receiver's Instance Variables		Combining Allocation and Initialization
	Polymorphism		Deallocation
	Dynamic Binding	<b>137</b>	<b>Forwarding</b>
<b>51</b>	<b>Classes</b>		Forwarding and Multiple Inheritance
	Inheritance		Surrogate Objects
	Class Types		Making Forwarding Transparent
	Class Objects		
	Class Names in Source Code		

---

141	Dynamic Loading
<b>143</b>	<b>Chapter: Objective-C Language Summary</b>
145	Messages
145	Defined Types
146	Preprocessor Directives
146	Compiler Directives
148	Classes
148	Categories
149	Formal Protocols
150	Method Declarations
150	Method Implementations
151	Naming Conventions
<b>153</b>	<b>Chapter: Reference Manual for the Objective-C Language</b>
156	External Declarations
159	Type Specifiers
160	Type Qualifiers
160	Primary Expressions
<b>163</b>	<b>Glossary</b>
<b>169</b>	<b>INDEX</b>

---

---

---

Introduction



---

Object-oriented programming, like most interesting new developments, builds on some old ideas, extends them, and puts them together in novel ways. The result is many-faceted and a clear step forward for the art of programming. An object-oriented approach makes programs more intuitive to design, faster to develop, more amenable to modifications, and easier to understand. It leads not only to new ways of constructing programs, but also to new ways of conceiving the programming task.

Nevertheless, object-oriented programming presents some formidable obstacles to those who would like to understand what it's all about or begin trying it out. It introduces a new way of doing things that may seem strange at first, and it comes with an extensive terminology that can take some getting used to. The terminology will help in the end, but it's not always easy to learn. Moreover, there are as yet few full-fledged object-oriented development environments available to try out. It can be difficult to get started.

That's where this book comes in. It's designed to help you become familiar with object-oriented programming and get over the hurdle its terminology presents. It spells out some of the implications of object-oriented design and tries to give you a flavor of what writing an object-oriented program is really like. It fully documents the Objective-C™ language, an object-oriented programming language based on standard C, and introduces the most extensive object-oriented development environment currently available—OPENSTEP™.

The book is intended for readers who might be interested in:

- Learning about object-oriented programming,
- Finding out about the OPENSTEP development environment, or
- Programming in Objective-C.

NeXT supplies its own compiler for the Objective-C language (a modification of the GNU C compiler) and a run-time system to carry out the dynamic functions of the language. It has tested and made steady improvements to both over the years; this book describes the latest release, which includes provisions for declaring and adopting protocols and setting the scope of instance variables.

Throughout this manual and in other NeXT documentation, the term “Objective-C” refers to the language as implemented for the OPENSTEP development environment and presented here.

## The Development Environment

Every object-oriented development environment worthy of the name consists of at least three parts:

- A library of objects and software frameworks and kits
- A set of development tools
- An object-oriented programming language

OPENSTEP comes with an extensive library. It includes several software frameworks containing definitions for objects that you can use “off the shelf” or adapt to your program’s needs. These include the Foundation Framework, the Application Kit™ framework (for building a graphical user interface), and others.

OPENSTEP also includes some exceptional development tools for putting together applications. There’s Interface Builder™, a program that lets you design an application graphically and assemble its user interface on-screen, and Project Builder, a project-management program that provides graphical access to the compiler, the debugger, documentation, a program editor, and other tools.

This book is about the third component of the development environment—the programming language. All OPENSTEP software frameworks are written in the Objective-C language. To get the benefit of the frameworks, applications must also use Objective-C. You are not restricted entirely to Objective-C, however; you are free to incorporate C++ code into your applications as well.

Objective-C is implemented as set of extensions to the C language. It’s designed to give C a full capability for object-oriented programming, and to do so in a simple and straightforward way. Its additions to C are few and are mostly based on Smalltalk, one of the first object-oriented programming languages.

This book both introduces the object-oriented model that Objective-C is based upon and fully documents the language. It concentrates on the Objective-C extensions to C, not on the C language itself. There are many good books available on C; this manual doesn’t attempt to duplicate them.

Because this isn’t a book about C, it assumes some prior acquaintance with that language. However, it doesn’t have to be an extensive acquaintance. Object-oriented programming in Objective-C is sufficiently different from procedural programming in standard C that you won’t be hampered if you’re not an experienced C programmer.

---

## Why Objective-C

The Objective-C language was chosen for the OPENSTEP development environment for a variety of reasons. First and foremost, it's an object-oriented language. The kind of functionality that's packaged in the OPENSTEP software frameworks can only be delivered through object-oriented techniques. This manual will explain how the frameworks work and why this is the case.

Second, because Objective-C is an extension of standard ANSI C, existing C programs can be adapted to use the software frameworks without losing any of the work that went into their original development. Since Objective-C incorporates C, you get all the benefits of C when working within Objective-C. You can choose when to do something in an object-oriented way (define a new class, for example) and when to stick to procedural programming techniques (define a structure and some functions instead of a class).

Moreover, Objective-C is a simple language. Its syntax is small, unambiguous, and easy to learn. Object-oriented programming, with its self-conscious terminology and emphasis on abstract design, often presents a steep learning curve to new recruits. A well-organized language like Objective-C can make becoming a proficient object-oriented programmer that much less difficult. The size of this manual is a testament to the simplicity of Objective-C. It's not a big book—and Objective-C is fully documented in just two of its chapters.

Objective-C is the most dynamic of the object-oriented languages based on C. The compiler throws very little away, so a great deal of information is preserved for use at run time. Decisions that otherwise might be made at compile time can be postponed until the program is running. This gives Objective-C programs unusual flexibility and power. For example, Objective-C's dynamism yields two big benefits that are hard to get with other nominally object-oriented languages:

- Objective-C supports an open style of dynamic binding, a style that can accommodate a simple architecture for interactive user interfaces. Messages are not necessarily constrained by either the class of the receiver or the method selector, so a software framework can allow for user choices at run time and permit developers freedom of expression in their design. (Terminology like “dynamic binding,” “message,” “class,” “receiver,” and “selector” will be explained in due course in this manual.)
- Objective-C's dynamism enables the construction of sophisticated development tools. An interface to the run-time system provides access to information about running applications, so it's possible to develop tools that monitor, intervene, and reveal the underlying structure and activity of

Objective-C applications. Interface Builder could not have been developed with a less dynamic language.

## How the Manual is Organized

This manual is divided into four chapters and two appendices. The chapters are:

- Chapter 1, “Object-Oriented Programming,” discusses the rationale for object-oriented programming languages and introduces much of the terminology. It develops the ideas behind object-oriented programming techniques. If you’re already familiar with object-oriented programming and are interested only in Objective-C, you may want to skip this chapter and go directly to Chapter 2.
- Chapter 2, “The Objective-C Language,” describes the basic concepts and syntax of Objective-C. It covers many of the same topics as Chapter 1, but looks at them from the standpoint of the Objective-C language. It reintroduces the terminology of object-oriented programming, but in the context of Objective-C.
- Chapter 3, “Objective-C Extensions,” concentrates on two of the principal innovations introduced into the language as part of OPENSTEP Objective-C—categories and protocols. It also takes up static typing and lesser used aspects of the language.
- Chapter 4, “The Run-Time System,” looks at the NSObject class and how Objective-C programs interact with the run-time system. In particular, it examines the paradigms for allocating and initializing new objects, dynamically loading new classes at run time, and forwarding messages to other objects.

The appendices contain reference material that might be useful for understanding the language. They are:

- Appendix A, “Objective-C Language Summary,” lists and briefly comments on all of the Objective-C extensions to the C language.
- Appendix B, “Reference Manual for the Objective-C Language,” presents, without comment, a formal grammar of the Objective-C extensions to the C language. This reference manual is meant to be read as a companion to the reference manual for C presented in *The C Programming Language* by Brian W. Kernighan and Dennis M. Ritchie, published by Prentice Hall.

---

## Conventions

Where this manual discusses functions, methods, and other programming elements, it makes special use of bold and italic fonts. **Bold** denotes words or characters that are to be taken literally (typed as they appear). *Italic* denotes words that represent something else or can be varied. For example, the syntax

```
@interface ClassName ( CategoryName )
```

means that `@interface` and the two parentheses are required, but that you can choose the class name and category name. Where method syntax is shown, the method name is bold, parameters are italic, and other elements (mainly data types) are in regular font. For example:

```
- (void)encodeWithCoder:(NSCoder *)coder
```

Where example code is shown, ellipsis indicates the parts, often substantial parts, that have been omitted:

```
- (void)encodeWithCoder:(NSCoder *)coder
{
    [super encodeWithCoder:coder];
    . . .
}
```

The conventions used in the reference appendix are described in that appendix.



*Chapter 1*

Object-Oriented Programming



---

Programming languages have traditionally divided the world into two parts—data and operations on data. Data is static and immutable, except as the operations may change it. The procedures and functions that operate on data have no lasting state of their own; they're useful only in their ability to affect data.

This division is, of course, grounded in the way computers work, so it's not one that you can easily ignore or push aside. Like the equally pervasive distinctions between matter and energy and between nouns and verbs, it forms the background against which we work. At some point, all programmers—even object-oriented programmers—must lay out the data structures that their programs will use and define the functions that will act on the data.

With a procedural programming language like C, that's about all there is to it. The language may offer various kinds of support for organizing data and functions, but it won't divide the world any differently. Functions and data structures are the basic elements of design.

Object-oriented programming doesn't so much dispute this view of the world as restructure it at a higher level. It groups operations and data into modular units called *objects* and lets you combine objects into structured networks to form a complete program. In an object-oriented programming language, objects and object interactions are the basic elements of design.

Every object has both state (data) and behavior (operations on data). In that, they're not much different from ordinary physical objects. It's easy to see how a mechanical device, such as a pocket watch or a piano, embodies both state and behavior. But almost anything that's designed to do a job does too. Even simple things with no moving parts such as an ordinary bottle combine state (how full the bottle is, whether or not it's open, how warm its contents are) with behavior (the ability to dispense its contents at various flow rates, to be opened or closed, to withstand high or low temperatures).

It's this resemblance to real things that gives objects much of their power and appeal. They can not only model components of real systems, but equally as well fulfill assigned roles as components in software systems.

## Interface and Implementation

As humans, we're constantly faced with myriad facts and impressions that we must make sense of. To do so, we have to abstract underlying structure away from surface details and discover the fundamental relations at work.

Abstractions reveal causes and effects, expose patterns and frameworks, and separate what's important from what's not. They're at the root of understanding.

To invent programs, you need to be able to capture the same kinds of abstractions and express them in the program design.

It's the job of a programming language to help you do this. The language should facilitate the process of invention and design by letting you encode abstractions that reveal the way things work. It should let you make your ideas concrete in the code you write. Surface details shouldn't obscure the architecture of your program.

All programming languages provide devices that help express abstractions. In essence, these devices are ways of grouping implementation details, hiding them, and giving them, at least to some extent, a common interface—much as a mechanical object separates its interface from its implementation.

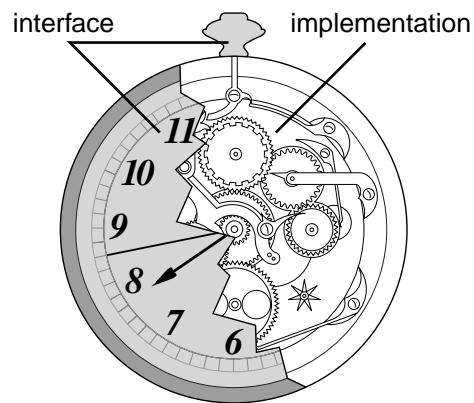

Looking at such a unit from the inside, as the implementor, you'd be concerned with what it's composed of and how it works. Looking at it from the outside, as the user, you're concerned only with what it is and what it does. You can look past the details and think solely in terms of the role that the unit plays at a higher level.

The principal units of abstraction in the C language are structures and functions. Both, in different ways, hide elements of the implementation:

- On the data side of the world, C structures group data elements into larger units which can then be handled as single entities. While some code must delve inside the structure and manipulate the fields separately, much of the program can regard it as a single thing—not as a collection of elements, but as what those elements taken together represent. One structure can include

---

others, so a complex arrangement of information can be built from simpler layers.

In modern C, the fields of a structure live in their own name space—that is, their names won't conflict with identically-named data elements outside the structure. Partitioning the program name space is essential for keeping implementation details out of the interface. Imagine, for example, the enormous task of assigning a different name to every piece of data in a large program and of making sure new names don't conflict with old ones.

- On the procedural side of the world, functions encapsulate behaviors that can be used repeatedly without being reimplemented. Data elements local to a function, like the fields within a structure, are protected within their own name space. Functions can reference (call) other functions, so quite complex behaviors can be built from smaller pieces.

Functions are reusable. Once defined, they can be called any number of times without again considering the implementation. The most generally useful functions can be collected in libraries and reused in many different applications. All the user needs is the function interface, not the source code.

However, unlike data elements, functions aren't partitioned into separate name spaces. Each function must have a unique name. Although the function may be reusable, its name is not.

C structures and functions are able to express significant abstractions, but they maintain the distinction between data and operations on data. In a procedural programming language, the highest units of abstraction still live on one side or the other of the data-versus-operations divide. The programs you design must always reflect, at the highest level, the way the computer works.

Object-oriented programming languages don't lose any of the virtues of structures and functions. But they go a step further and add a unit capable of abstraction at a higher level, a unit that hides the interaction between a function and its data.

Suppose, for example, that you have a group of functions that all act on a particular data structure. You want to make those functions easier to use by, as far as possible, taking the structure out of the interface. So you supply a few additional functions to manage the data. All the work of manipulating the data structure—allocating it, initializing it, getting information from it, modifying values within it, keeping it up to date, and freeing it—is done through the functions. All the user does is call the functions and pass the structure to them.

With these changes, the structure has become an opaque token that other programmers never need to look inside. They can concentrate on what the functions do, not how the data is organized. You've taken the first step toward creating an object.

The next step is to give this idea support in the programming language and completely hide the data structure so that it doesn't even have to be passed between the functions. The data becomes an internal implementation detail; all that's exported to users is a functional interface. Because objects completely encapsulate their data (hide it), users can think of them solely in terms of their behavior.

With this step, the interface to the functions has become much simpler. Callers don't need to know how they're implemented (what data they use). It's fair now to call this an "object."

The hidden data structure unites all of the functions that share it. So an object is more than a collection of random functions; it's a bundle of related behaviors that are supported by shared data. To use a function that belongs to an object, you first create the object (thus giving it its internal data structure), then tell the object which function it should invoke. You begin to think in terms of what the object does, rather than in terms of the individual functions.

This progression from thinking about functions and data structures to thinking about object behaviors is the essence of object-oriented programming. It may seem unfamiliar at first, but as you gain experience with object-oriented programming, you'll find it's a more natural way to think about things. Everyday programming terminology is replete with analogies to real-world objects of various kinds—lists, containers, tables, controllers, even managers. Implementing such things as programming objects merely extends the analogy in a natural way.

A programming language can be judged by the kinds of abstractions that it enables you to encode. You shouldn't be distracted by extraneous matters or forced to express yourself using a vocabulary that doesn't match the reality you're trying to capture.

If, for example, you must always tend to the business of keeping the right data matched with the right procedure, you're forced at all times to be aware of the entire program at a low level of implementation. While you might still invent programs at a high level of abstraction, the path from imagination to implementation can become quite tenuous—and more and more difficult as programs become bigger and more complicated.

---

By providing another, higher level of abstraction, object-oriented programming languages give you a larger vocabulary and a richer model to program in.

## The Object Model

The insight of object-oriented programming is to combine state and behavior—data and operations on data—in a high-level unit, an *object*, and to give it language support. An object is a group of related functions and a data structure that serves those functions. The functions are known as the object's *methods*, and the fields of its data structure are its *instance variables*. The methods wrap around the instance variables and hide them from the rest of the program:

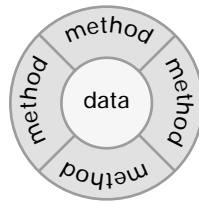

Likely, if you've ever tackled any kind of difficult programming problem, your design has included groups of functions that work on a particular kind of data—implicit “objects” without the language support. Object-oriented programming makes these function groups explicit and permits you to think in terms of the group, rather than its components. The only way to an object's data, the only interface, is through its methods.

By combining both state and behavior in a single unit, an object becomes more than either alone; the whole really is greater than the sum of its parts. An object is a kind of self-sufficient “subprogram” with jurisdiction over a specific functional area. It can play a full-fledged modular role within a larger program design.

### Terminology

Object-oriented terminology varies from language to language. For example, in C++ methods are called “member functions” and

instance variables are “data members.” This manual uses the terminology of Objective-C, which has its basis in Smalltalk.

For example, if you were to write a program that modeled home water usage, you might invent objects to represent the various components of the water-delivery system. One might be a Faucet object that would have methods to start and stop the flow of water, set the rate of flow, return the amount of water consumed in a given period, and so on. To do this work, a Faucet object would need instance variables to keep track of whether the tap is open or shut, how much water is being used, and where the water is coming from.

Clearly, a programmatic Faucet can be smarter than a real one (it's analogous to a mechanical faucet with lots of gauges and instruments attached). But even a real faucet, like any system component, exhibits both state and behavior. To effectively model a system, you need programming units, like objects, that also combine state and behavior.

A program consists of a network of interconnected objects that call upon each other to solve a part of the puzzle. Each object has a specific role to play in the overall design of the program and is able to communicate with other objects. Objects communicate through *messages*, requests to perform a method.

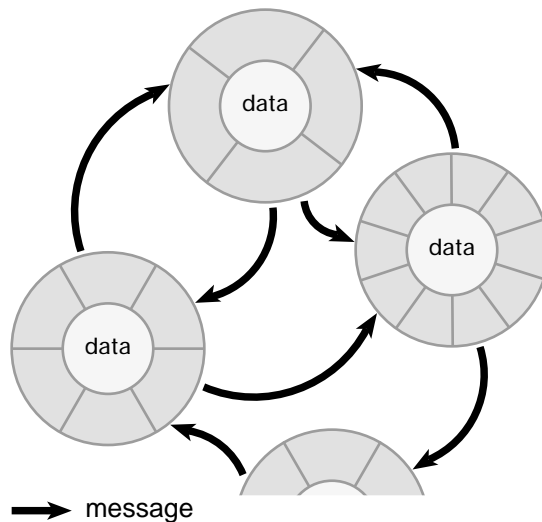

The objects in the network won't all be the same. For example, in addition to Faucets, the program that models water usage might also have WaterPipe objects that can deliver water to the Faucets and Valve objects to regulate the flow among WaterPipes. There could be a Building object to coordinate a set of WaterPipes, Valves, and Faucets, some Appliance objects—corresponding to dishwashers, toilets, and washing machines—that can turn Valves on and off, and maybe some Users to work the Appliances and Faucets. When a Building object is asked how much water is being used, it might call upon each Faucet

---

and Valve to report its current state. When a User starts up an Appliance, the Appliance will need to turn on a Valve to get the water it requires.

### The Messaging Metaphor

Every programming paradigm comes with its own terminology and metaphors. None more so than object-oriented programming. Its jargon invites you to think about what goes on in a program from a particular perspective.

There's a tendency, for example, to think of objects as "actors" and to endow them with human-like intentions and abilities. It's tempting sometimes to talk about an object "deciding" what to do about a situation, "asking" other objects for information, "introspecting" about itself to get requested information, "delegating" responsibility to another object, or "managing" a process.

Rather than think in terms of functions or methods doing the work, as you would in a procedural programming language, this metaphor asks you to think of objects as "performing" their methods. Objects are not passive containers for state and behavior, but are said to be the agents of the program's activity.

This is actually a useful metaphor. An object is like an actor in a couple of respects: It has a particular role to play within the overall design of the program, and within that role it can act fairly independently of the other parts of the program. It interacts with other objects as they play their own roles, but is self-contained and to a certain extent can act on its own. Like an actor on stage, it can't stray from the script, but the role it plays it can be multi-faceted and quite complex.

The idea of objects as actors fits nicely with the principal metaphor of object-oriented programming—the idea that objects communicate through "messages." Instead of calling a method as you would a function, you send a message to an object requesting it to perform one of its methods.

Although it can take some getting used to, this metaphor leads to a useful way of looking at methods and objects. It abstracts methods away from the particular data they act on and concentrates on behavior instead. For example, in an object-oriented programming interface, a start method might initiate an operation, an archive method might archive information, and a draw method might produce an image. Exactly which operation is initiated, which information is archived, and which image is drawn isn't revealed by the method name. Different objects might perform these methods in different ways.

Thus, methods are a vocabulary of abstract behaviors. To invoke one of those behaviors, you have to make it concrete by associating the method with an object. This is done by naming the object as the "receiver" of a message. The

object you choose as receiver will determine the exact operation that's initiated, the data that's archived, or the image that's drawn.

Since methods belong to objects, they can be invoked only through a particular receiver (the owner of the method and of the data structure the method will act on). Different receivers can have different implementations of the same method, so different receivers can do different things in response to the same message. The result of a message can't be calculated from the message or method name alone; it also depends on the object that receives the message.

By separating the message (the requested behavior) from the receiver (the owner of a method that can respond to the request), the messaging metaphor perfectly captures the idea that behaviors can be abstracted away from their particular implementations.

### Classes

A program can have more than one object of the same kind. The program that models water usage, for example, might have several Faucets and WaterPipes and perhaps a handful of Appliances and Users. Objects of the same kind are said to belong to the same *class*. All members of a class are able to perform the same methods and have matching sets of instance variables. They also share a common definition; each kind of object is defined just once.

In this, objects are similar to C structures. Declaring a structure defines a type. For example, this declaration

```
struct key {
    char *word;
    int count;
};
```

defines the `struct key` type. Once defined, the structure name can be used to produce any number of instances of the type:

```
struct key a, b, c, d;
struct key *p = malloc(sizeof(struct key) * MAXITEMS);
```

The declaration is a template for a kind of structure, but it doesn't create a structure that the program can use. It takes another step to allocate memory for an actual structure of that type, a step that can be repeated any number of times.

---

Similarly, defining an object creates a template for a kind of object. It defines a *class* of objects. The template can be used to produce any number of similar objects—*instances* of the class. For example, there would be a single definition of the Faucet class. Using this definition, a program could allocate as many Faucet instances as it needed.

A class definition is like a structure definition in that it lays out an arrangement of data elements (instance variables) that become part of every instance. Each instance has memory allocated for its own set of instance variables, which store values peculiar to the instance.

However, a class definition differs from a structure declaration in that it also includes methods that specify the behavior of class members. Every instance is characterized by its access to the methods defined for the class. Two objects with equivalent data structures but different methods would not belong to the same class.

### Modularity

To a C programmer, a “module” is nothing more than a file containing source code. Breaking a large (or even not-so-large) program into different files is a convenient way of splitting it into manageable pieces. Each piece can be worked on independently and compiled alone, then integrated with other pieces when the program is linked. Using the static storage class designator to limit the scope of names to just the files where they’re declared enhances the independence of source modules.

This kind of module is a unit defined by the file system. It’s a container for source code, not a logical unit of the language. What goes into the container is up to each programmer. You can use them to group logically related parts of the code, but you don’t have to. Files are like the drawers of a dresser; you can put your socks in one drawer, underwear in another, and so on, or you can use another organizing scheme or simply choose to mix everything up.

#### Access To Methods

It’s convenient to think of methods as being part of an object, just as instance variables are. As in the previous figure, methods can be diagrammed as surrounding the object’s instance variables.

But, of course, methods aren’t grouped with instance variables in memory. Memory is allocated for the instance variables of each

new object, but there’s no need to allocate memory for methods. All an instance needs is *access* to its methods, and all instances of the same class share access to the same set of methods. There’s only one copy of the methods in memory, no matter how many instances of the class are created.

Object-oriented programming languages support the use of file containers for source code, but they also add a logical module to the language—class definitions. As you'd expect, it's often the case that each class is defined in its own source file—logical modules are matched to container modules.

In Objective-C, for example, it would be possible to define the part of the Valve class that interacts with WaterPipes in the same file that defines the WaterPipe class, thus creating a container module for WaterPipe-related code and splitting Valve class into more than one file. The Valve class definition would still act as a modular unit within the construction of the program—it would still be a logical module—no matter how many files the source code was located in.

The mechanisms that make class definitions logical units of the language are discussed in some detail under “Mechanisms Of Abstraction” below.

### Reusability

A principal goal of object-oriented programming is to make the code you write as reusable as possible—to have it serve many different situations and applications—so that you can avoid reimplementing, even if in only slightly different form, something that's already been done.

Reusability is influenced by a variety of different factors, including:

- How reliable and bug-free the code is
- How clear the documentation is
- How simple and straightforward the programming interface is
- How efficiently the code performs its tasks
- How full the feature set is

Clearly, these factors don't apply just to the object model. They can be used to judge the reusability of any code—standard C functions as well as class definitions. Efficient and well documented functions, for example, would be more reusable than undocumented and unreliable ones.

Nevertheless, a general comparison would show that class definitions lend themselves to reusable code in ways that functions do not. There are various things you can do to make functions more reusable—passing data as arguments rather than assuming specifically-named global variables, for example. Even so, it turns out that only a small subset of functions can be generalized beyond the applications they were originally designed for. Their reusability is inherently limited in at least three ways:

- Function names are global variables; each function must have a unique name (except for those declared `static`). This makes it difficult to rely heavily on library code when building a complex system. The programming interface

---

would be hard to learn and so extensive that it couldn't easily capture significant generalizations.

Classes, on the other hand, can share programming interfaces. When the same naming conventions are used over and over again, a great deal of functionality can be packaged with a relatively small and easy-to-understand interface.

- Functions are selected from a library one at a time. It's up to programmers to pick and choose the individual functions they need.

In contrast, objects come as packages of functionality, not as individual methods and instance variables. They provide integrated services, so users of an object-oriented library won't get bogged down piecing together their own solutions to a problem.

- Functions are typically tied to particular kinds of data structures devised for a specific program. The interaction between data and function is an unavoidable part of the interface. A function is useful only to those who agree to use the same kind of data structures it accepts as arguments.

Because it hides its data, an object doesn't have this problem. This is one of the principal reasons why classes can be reused more easily than functions.

An object's data is protected and won't be touched by any other part of the program. Methods can therefore trust its integrity. They can be sure that external access hasn't put it in an illogical or untenable state. This makes an object data structure more reliable than one passed to a function, so methods can depend on it more. Reusable methods are consequently easier to write.

Moreover, because an object's data is hidden, a class can be reimplemented to use a different data structure without affecting its interface. All programs that use the class can pick up the new version without changing any source code; no reprogramming is required.

#### Mechanisms Of Abstraction

To this point, objects have been introduced as units that embody higher-level abstractions and as coherent role-players within an application. However, they couldn't be used this way without the support of various language mechanisms. Two of the most important mechanisms are:

- Encapsulation, and
- Polymorphism.

Encapsulation keeps the implementation of an object out of its interface, and polymorphism results from giving each class its own name space. The following sections discuss each of these mechanisms in turn.

### Encapsulation

To design effectively at any level of abstraction, you need to be able to leave details of implementation behind and think in terms of units that group those details under a common interface. For a programming unit to be truly effective, the barrier between interface and implementation must be absolute. The interface must *encapsulate* the implementation—hide it from other parts of the program. Encapsulation protects an implementation from unintended actions and inadvertent access.

In C, a function is clearly encapsulated; its implementation is inaccessible to other parts of the program and protected from whatever actions might be taken outside the body of the function. Method implementations are similarly encapsulated, but, more importantly, so are an object's instance variables. They're hidden inside the object and invisible outside it. The encapsulation of instance variables is sometimes also called *information hiding*.

It might seem, at first, that hiding the information in instance variables would constrain your freedom as a programmer. Actually, it gives you more room to act and frees you from constraints that might otherwise be imposed. If any part of an object's implementation could leak out and become accessible or a concern to other parts of the program, it would tie the hands both of the object's implementor and of those who would use the object. Neither could make modifications without first checking with the other.

Suppose, for example, that you're interested in the Faucet object being developed for the program that models water use and you want to incorporate it in another program you're writing. Once the interface to the object is decided, you don't have to be concerned as others work on it, fix bugs, and find better ways to implement it. You'll get the benefit of these improvements, but none of them will affect what you do in your program. Because you're depending solely on the interface, nothing they do can break your code. Your program is insulated from the object's implementation.

Moreover, although those implementing the Faucet object would be interested in how you're using the class and might try to make sure that it meet your needs, they don't have to be concerned with the way you're writing your code. Nothing you do can touch the implementation of the object or limit their freedom to make changes in future releases. The implementation is insulated from anything that you or other users of the object might do.

---

## Polymorphism

This ability of different objects to respond, each in its own way, to identical messages is called *polymorphism*.

Polymorphism results from the fact that every class lives in its own name space. The names assigned within a class definition won't conflict with names assigned anywhere outside it. This is true both of the instance variables in an object's data structure and of the object's methods:

- Just as the fields of a C structure are in a protected name space, so are an object's instance variables.
- Method names are also protected. Unlike the names of C functions, method names aren't global symbols. The name of a method in one class can't conflict with method names in other classes; two very different classes could implement identically named methods.

Method names are part of an object's interface. When a message is sent requesting an object to do something, the message names the method the object should perform. Because different objects can have different methods with the same name, the meaning of a message must be understood relative to the particular object that receives the message. The same message sent to two different objects could invoke two different methods.

The main benefit of polymorphism is that it simplifies the programming interface. It permits conventions to be established that can be reused in class after class. Instead of inventing a new name for each new function you add to a program, the same names can be reused. The programming interface can be described as a set of abstract behaviors, quite apart from the classes that implement them.

### Overloading

The terms "polymorphism" and "argument overloading" refer basically to the same thing, but from slightly different points of view. Polymorphism takes a pluralistic point of view and notes that several classes can each have a method with the same name. Argument overloading takes the point of the view of the method name and notes that it can have different effects depending on

what kind of object it applies to.

Operator overloading is similar. It refers to the ability to turn operators of the language (such as '=' and '+' in C) into methods that can be assigned particular meanings for particular kinds of objects. Objective-C implements polymorphism of method names, but not operator overloading.

For example, instead of defining an `amountConsumed` method for an `Appliance` object to report the amount of water it uses over a given period of time, an `amountDispensedAtFaucet` method for a `Faucet` to report virtually the same thing, and a `cumulativeUsage` method for the `Building` object to report the cumulative total for the whole building—requiring programmers to learn three different names for what is conceptually the same operation—each class can simply have a `waterUsed` method.

Polymorphism also permits code to be isolated in the methods of different objects rather than be gathered in a single function that enumerates all the possible cases. This makes the code you write more extensible and reusable. When a new case comes along, you don't have to reimplement existing code, but only add a new class with a new method, leaving the code that's already written alone.

For example, suppose you have code that sends a `draw` message to an object. Depending on the receiver, the message might produce one of two possible images. When you want to add a third case, you don't have to change the message or alter existing code, but merely allow another object to be assigned as the message receiver.

### Inheritance

The easiest way to explain something new is to start with something old. If you want to describe what a “schooner” is, it helps if your listeners already know what “sailboat” means. If you want to explain how a harpsichord works, it's best if you can assume your audience has already looked inside a piano, or has seen a guitar played, or at least is familiar with the idea of a “musical instrument.”

The same is true if you want to define a new kind of object; the description is simpler if it can start from the definition of an existing object.

With this in mind, object-oriented programming languages permit you to base a new class definition on a class already defined. The base class is called a *superclass*; the new class is its *subclass*. The subclass definition specifies only how it differs from the superclass; everything else is taken to be the same.

Nothing is copied from superclass to subclass. Instead, the two classes are connected so that the subclass *inherits* all the methods and instance variables of its superclass, much as you want your listener's understanding of “schooner” to inherit what they already know about sailboats. If the subclass definition were empty (if it didn't define any instance variables or methods of its own), the two classes would be identical (except for their names) and share the same definition. It would be like explaining what a “fiddle” is by saying that it's exactly the same as a “violin.” However, the reason for declaring a subclass isn't

---

to generate synonyms, but to create something at least a little different from its superclass. You'd want to let the fiddle play bluegrass in addition to classical music.

### Class Hierarchies

Any class can be used as a superclass for a new class definition. A class can simultaneously be a subclass of another class and a superclass for its own subclasses. Any number of classes can thus be linked in a hierarchy of inheritance.

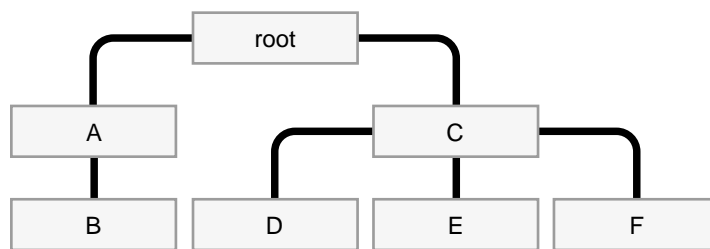

As the above figure shows, every inheritance hierarchy begins with a root class that has no superclass. From the root class, the hierarchy branches downward. Each class inherits from its superclass, and through its superclass, from all the classes above it in the hierarchy. Every class inherits from the root class.

Each new class is the accumulation of all the class definitions in its inheritance chain. In the example above, class D inherits both from C, its superclass, and the root class. Members of the D class will have methods and instance variables defined in all three classes—D, C, and root.

Typically, every class has just one superclass and can have an unlimited number of subclasses. However, in some object-oriented programming languages (though not in Objective-C), a class can have more than one superclass; it can inherit through multiple sources. Instead of a single hierarchy that branches downward as shown in the above figure, multiple inheritance lets some branches of the hierarchy (or of different hierarchies) merge.

### Subclass Definitions

A subclass can make three kinds of changes to the definition it inherits through its superclass:

- It can expand the class definition it inherits by adding new methods and instance variables. This is the most common reason for defining a subclass.

Subclasses always add new methods, and new instance variables if the methods require it.

- It can modify the behavior it inherits by replacing an existing method with a new version. This is done by simply implementing a new method with the same name as one that's inherited. The new version *overrides* the inherited version. (The inherited method doesn't disappear; it's still valid for the class that defined it and other classes that inherit it.)
- It can refine or extend the behavior it inherits by replacing an existing method with a new version, but still retain the old version by incorporating it in the new method. This is done by sending a message to perform the old version in the body of the new method. Each class in an inheritance chain can contribute part of a method's behavior. In the previous figure, for example, class D might override a method defined in class C and incorporate C's version, while C's version incorporates a version defined in the root class.

Subclasses thus tend to fill out a superclass definition, making it more specific and specialized. They add, and sometimes replace, code rather than subtract it. Note that methods generally can't be disinherited and instance variables can't be removed or overridden.

### Uses of Inheritance

The classic examples of an inheritance hierarchy are borrowed from animal and plant taxonomies. For example, there could a class corresponding to the Pinaceae (pine) family of trees. Its subclasses could be Fir, Spruce, Pine, Hemlock, Tamarack, DouglasFir, and TrueCedar, corresponding to the various genera that make up the family. The Pine class might have SoftPine and HardPine subclasses, with WhitePine, SugarPine, and BristleconePine as subclasses of SoftPine, and PonderosaPine, JackPine, MontereyPine, and RedPine as subclasses of HardPine.

There's rarely a reason to program a taxonomy like this, but the analogy is a good one. Subclasses tend to specialize a superclass or adapt it to a special purpose, much as a species specializes a genus.

Here are some typical uses of inheritance:

- Reusing code. If two or more classes have some things in common but also differ in some ways, the common elements can be put in an a single class definition that the other classes inherit. The common code is shared and need only be implemented once.

For example, Faucet, Valve, and WaterPipe objects, defined for the program that models water use, all need a connection to a water source and they all

---

should be able to record the rate of flow. These commonalities can be encoded once, in a class that the Faucet, Valve, and WaterPipe classes inherit from. A Faucet can be said to be a kind of Valve, so perhaps the Faucet class would inherit most of what it is from Valve, and add very little of its own.

- Setting up a protocol. A class can declare a number of methods that its subclasses are expected to implement. The class might have empty versions of the methods, or it might implement partial versions that are to be incorporated into the subclass methods. In either case, its declarations establish a *protocol* that all its subclasses must follow.

When different classes implement similarly named methods, a program is better able to make use of polymorphism in its design. Setting up a protocol that subclasses must implement helps enforce these naming conventions.

- Delivering generic functionality. One implementor can define a class that contains a lot of basic, general code to solve a problem, but doesn't fill in all the details. Other implementors can then create subclasses to adapt the generic class to their specific needs. For example, the Appliance class in the program that models water use might define a generic water-using device that subclasses would turn into specific kinds of appliances.

Inheritance is thus both a way to make someone else's programming task easier and a way to separate levels of implementation.

- Making slight modifications. When inheritance is used to deliver generic functionality, set up a protocol, or reuse code, a class is devised that other classes are expected to inherit from. But you can also use inheritance to modify classes that aren't intended as superclasses. Suppose, for example, that there's an object that would work well in your program, but you'd like to change one or two things that it does. You can make the changes in a subclass.
- Previewing possibilities. Subclasses can also be used to factor out alternatives for testing purposes. For example, if a class is to be encoded with a particular user interface, alternative interfaces can be factored into subclasses during the design phase of the project. Each alternative can then be demonstrated to potential users to see which they prefer. When the choice is made, the selected subclass can be reintegrated into its superclass.

## Dynamism

At one time in programming history, the question of how much memory a program would use was settled when the source code was compiled and linked. All the memory the program would ever need was set aside for it as it was launched. This memory was fixed; it could neither grow nor shrink.

In hindsight, it's evident what a serious constraint this was. It limited not only how programs were constructed, but what you could imagine a program doing. It constrained design, not just programming technique. Functions (like `malloc()`) that dynamically allocate memory as a program runs opened possibilities that didn't exist before.

Compile-time and link-time constraints are limiting because they force issues to be decided from information found in the programmer's source code, rather than from information obtained from the user as the program runs.

Although dynamic allocation removes one such constraint, many others, equally as limiting as static memory allocation, remain. For example, the elements that make up an application must be matched to data types at compile time. And the boundaries of an application are typically set at link time. Every part of the application must be united in a single executable file. New modules and new types can't be introduced as the program runs.

Object-oriented programming seeks to overcome these limitations and to make programs as dynamic and fluid as possible. It shifts much of the burden of decision making from compile time and link time to run time. The goal is to let program users decide what will happen, rather than constrain their actions artificially by the demands of the language and the needs of the compiler and linker.

Three kinds of dynamism are especially important for object-oriented design:

- Dynamic typing, waiting until run time to determine the class of an object
- Dynamic binding, determining at run time what method to invoke
- Dynamic loading, adding new components to a program as it runs

### Dynamic Typing

The compiler typically complains if the code you write assigns a value to a type that can't accommodate it. You might see warnings like these:

```
incompatible types in assignment
assignment of integer from pointer lacks a cast
```

Type checking is useful, but there are times when it can interfere with the benefits you get from polymorphism, especially if the type of every object must be known to the compiler.

Suppose, for example, that you want to send an object a message to perform the start method. Like other data elements, the object is represented by a variable.

---

If the variable's type (its class) must be known at compile time, it would be impossible to let run-time factors influence the decision about what kind of object should be assigned to the variable. If the class of the variable is fixed in source code, so is the version of `start` that the message invokes.

If, on the other hand, it's possible to wait until run time to discover the class of the variable, any kind of object could be assigned to it. Depending on the class of the receiver, the `start` message might invoke different versions of the method and produce very different results.

Dynamic typing thus gives substance to dynamic binding (discussed next). But it does more than that. It permits associations between objects to be determined at run time, rather than forcing them to be encoded in a static design. For example, a message could pass an object as an argument without declaring exactly what kind of object it is—that is, without declaring its class. The message receiver might then send its own messages to the object, again without ever caring about what kind of object it is. Because the receiver uses the object it's passed to do some of its work, it is in a sense customized by an object of indeterminate type (indeterminate in source code, that is, not at run time).

### Dynamic Binding

In standard C, you can declare a set of alternative functions, like the standard string-comparison functions,

```
int strcmp(const char *, const char *); /* case sensitive */
int strcasecmp(const char *, const char *); /*case insensitive*/
```

and declare a pointer to a function that has the same return and argument types:

```
int (* compare)(const char *, const char *);
```

You can then wait until run time to determine which function to assign to the pointer,

```
if ( **argv == 'i' )
    compare = strcasecmp;
else
    compare = strcmp;
```

and call the function through the pointer:

```
if ( compare(s1, s2) )  
    . . .
```

This is akin to what in object-oriented programming is called *dynamic binding*, delaying the decision of exactly which method to perform until the program is running.

Although not all object-oriented languages support it, dynamic binding can be routinely and transparently accomplished through messaging. You don't have to go through the indirection of declaring a pointer and assigning values to it as shown in the example above. You also don't have to assign each alternative procedure a different name.

Messages invoke methods indirectly. Every message expression must find a method implementation to "call." To find that method, the messaging machinery must check the class of the receiver and locate its implementation of the method named in the message. When this is done at run time, the method is dynamically bound to the message. When it's done by the compiler, the method is statically bound.

### Late Binding

Some object-oriented programming languages (notably C++) require a message receiver to be statically typed in source code, but don't require the type to be exact. An object can be typed to its own class or to any class that it inherits from.

The compiler therefore can't tell whether the message receiver is an instance of the class specified in the type declaration, an instance of a subclass, or an instance of some more distantly derived class. Since it doesn't know the exact class of the receiver, it can't know which version of the method named in the message to invoke.

In this circumstance, the choice is between treating the receiver as if it were an instance of the specified class and simply bind the method defined for that class to the message, or waiting until some later time to resolve the situation. In C++, the decision is postponed to link time for methods (member functions) that are declared **virtual**.

This is sometimes referred to as "late binding" rather than "dynamic binding." While "dynamic" in the sense that it happens at run time, it carries with it strict compile-time type constraints. As discussed here (and implemented in Objective-C), "dynamic binding" is unconstrained.

---

Dynamic binding is possible even in the absence of dynamic typing, but it's not very interesting. There's little benefit in waiting until run time to match a method to a message when the class of the receiver is fixed and known to the compiler. The compiler could just as well find the method itself; the run-time result won't be any different.

However, if the class of the receiver is dynamically typed, there's no way for the compiler to determine which method to invoke. The method can be found only after the class of the receiver is resolved at run time. Dynamic typing thus entails dynamic binding.

Dynamic typing also makes dynamic binding interesting, for it opens the possibility that a message might have very different results depending on the class of the receiver. Run-time factors can influence the choice of receiver and the outcome of the message.

Dynamic typing and binding also open the possibility that the code you write can send messages to objects not yet invented. If object types don't have to be decided until run time, you can give others the freedom to design their own classes and name their own data types, and still have your code send messages to their objects. All you need to agree on are the messages, not the data types.

**Note:** Dynamic binding is routine in Objective-C. You don't need to arrange for it specially, so your design never needs to bother with what's being done when.

### **Dynamic Loading**

The usual rule has been that, before a program can run, all its parts must be linked together in one file. When it's launched, the entire program is loaded into memory at once.

Some object-oriented programming environments overcome this constraint and allow different parts of an executable program to be kept in different files. The program can be launched in bits and pieces as they're needed. Each piece is *dynamically loaded* and linked with the rest of program as it's launched. User actions can determine which parts of the program are in memory and which aren't.

Only the core of a large program needs to be loaded at the start. Other modules can be added as the user requests their services. Modules the user doesn't request make no memory demands on the system.

Dynamic loading raises interesting possibilities. For example, an entire program wouldn't have to be developed at once. You could deliver your software in pieces and update one part of it at a time. You could devise a program that groups many different tools under a single interface, and load just the tools the user wants.

The program could even offer sets of alternative tools to do the same job. The user would select one tool from the set and only that tool would be loaded. It's not hard to imagine the possibilities. But because dynamic loading is relatively new, it's harder to predict its eventual benefits.

Perhaps the most important current benefit of dynamic loading is that it makes applications extensible. You can allow others to add to and customize a program you've designed. All your program needs to do is provide a framework that others can fill in, then at run time find the pieces that they've implemented and load them dynamically.

For example, in the OPENSTEP for Mach environment, Interface Builder dynamically loads custom palettes and inspectors, and the Workspace Manager™ dynamically loads inspectors for particular file formats. Anyone can design their own custom palettes and inspectors that these applications will load and incorporate into themselves.

The main challenge that dynamic loading faces is getting a newly loaded part of a program to work with parts already running, especially when the different parts were written by different people. However, much of this problem disappears in an object-oriented environment because code is organized into logical modules with a clear division between implementation and interface. When classes are dynamically loaded, nothing in the newly loaded code can clash with the code already in place. Each class encapsulates its implementation and has an independent name space.

In addition, dynamic typing and dynamic binding let classes designed by others fit effortlessly into the program you've designed. Once a class is dynamically loaded, it's treated no differently than any other class. Your code can send messages to their objects and theirs to yours. Neither of you has to know what classes the other has implemented. You need only agree on a communications protocol.

### Loading and Linking

Although it's the term commonly used, "dynamic loading" could just as well be called, "dynamic linking." Programs are linked when their various parts are joined so that they can work together; they're loaded when they're read into volatile memory at

launch time. Linking usually precedes loading. Dynamic loading refers to the process of separately loading new or additional parts of a program and linking them dynamically to the parts already running.

---

## Structuring Programs

Object-oriented programs have two kinds of structure. One can be seen in the inheritance hierarchy of class definitions. The other is evident in the pattern of message passing as the program runs. These messages reveal a network of object connections.

- The inheritance hierarchy explains how objects are related by type. For example, in the program that models water use, it might turn out that Faucets and WaterPipes are the same kind of object, except that Faucets can be turned on and off and WaterPipes can have multiple connections to other WaterPipes. This similarity would be captured in the program design if the Faucet and WaterPipe classes inherit from a common antecedent.
- The network of object connections explains how the program works. For example, Appliance objects might send messages requesting water to Valves, and Valves to WaterPipes. WaterPipes might communicate with the Building object, and the Building object with all the Valves, Faucets, and WaterPipes, but not directly with Appliances. To communicate with each other in this way, objects must know about each other. An Appliance would need a connection to a Valve, and a Valve to a WaterPipe, and so on. These connections define a program structure.

Object-oriented programs are designed by laying out the network of objects with their behaviors and patterns of interaction, and by arranging the hierarchy of classes. There's structure both in the program's activity and in its definition.

### Outlet Connections

Part of the task of designing an object-oriented program is to arrange the object network. The network doesn't have to be static; it can change dynamically as the program runs. Relationships between objects can be improvised as needed, and the cast of objects that play assigned roles can change from time to time. But there has to be a script.

Some connections can be entirely transitory. A message might contain an argument identifying an object, perhaps the sender of the message, that the receiver can communicate with. As it responds to the message, the receiver can send messages to that object, perhaps identifying itself or still another object that that object can in turn communicate with. Such connections are fleeting; they last only as long as the chain of messages.

But not all connections between objects can be handled on the fly. Some need to be recorded in program data structures. There are various ways to do this. A

table might be kept of object connections, or there might be a service that identifies objects by name. However, the simplest way is for each object to have instance variables that keep track of the other objects it must communicate with. These instance variables—termed *outlets* because they record the outlets for messages—define the principal connections between objects in the program network.

Although the names of outlet instance variables are arbitrary, they generally reflect the roles that outlet objects play. The figure below illustrates an object with four outlets—an “agent,” a “friend,” a “neighbor,” and a “boss.” The objects that play these parts may change every now and then, but the roles remain the same.

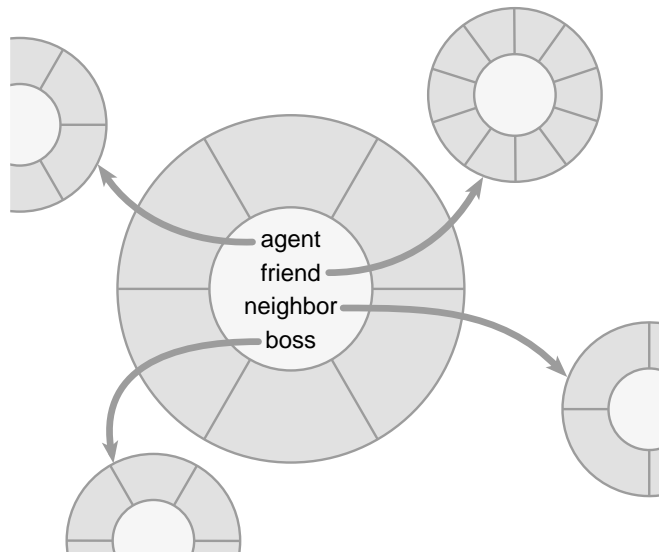

Some outlets are set when the object is first initialized and may never change. Others might be set automatically as the consequence of other actions. Still others can be set freely, using methods provided just for that purpose.

However they're set, outlet instance variables reveal the structure of the application. They link objects into a communicating network, much as the components of a water system are linked by their physical connections or as individuals are linked by their patterns of social relations.

### Extrinsic and Intrinsic Connections

Outlet connections can capture many different kinds of relationships between objects. Sometimes the connection is between objects that communicate more or less as equal partners in an application, each with its own role to play and

---

neither dominating the other. For example, an Appliance object might have an outlet instance variable to keep track of the Valve it's connected to.

Sometimes one object should be seen as being part of another. For example, a Faucet might use a Meter object to measure the amount of water being released. The Meter would serve no other object and would act only under orders from the Faucet. It would be an intrinsic part of the Faucet, in contrast to an Appliance's extrinsic connection to a Valve.

Similarly, an object that oversees other objects might keep a list of its charges. A Building object, for example, might have a list of all the WaterPipes in the program. The WaterPipes would be considered an intrinsic part of the Building and belong to it. WaterPipes, on the other hand, would maintain extrinsic connections to each other.

Intrinsic outlets behave differently than extrinsic ones. When an object is freed or archived in a file on disk, the objects that its intrinsic outlets point to must be freed or archived with it. For example, when a Faucet is freed, its Meter is rendered useless and therefore should be freed as well. A Faucet that was archived without its Meter would be of little use when it was unarchived again (unless it could create a new Meter for itself).

Extrinsic outlets, on the other hand, capture the organization of the program at a higher level. They record connections between relatively independent program subcomponents. When an Appliance is freed, the Valve it was connected to still is of use and remains in place. When an Appliance is unarchived, it can be connected to another Valve and resume playing the same sort of role it played before.

### **Activating the Object Network**

The object network is set into motion by an external stimulus. If you're writing an interactive application with a user interface, it will respond to user actions on the keyboard and mouse. A program that tries to factor very large numbers might start when you pass it a target number on the command line. Other programs might respond to data received over a phone line, information obtained from a database, or information about the state of a mechanical process the program monitors.

Object-oriented programs often are activated by a flow of *events*, reports of external activity of some sort. Applications that display a user interface are driven by events from the keyboard and mouse. Every touch of a key or click of the mouse generates events that the application receives and responds to. An object-oriented program structure (a network of objects that's prepared to

respond to an external stimulus) is ideally suited for this kind of user-driven application.

### Aggregation and Decomposition

Another part of the design task is deciding the arrangement of classes—when to add functionality to an existing class by defining a subclass and when to define an independent class. The problem can be clarified by imagining what would happen in the extreme case:

- It's possible to conceive of a program consisting of just one object. Since it's the only object, it can send messages only to itself. It therefore can't take advantage of polymorphism, or the modularity of a variety of classes, or a program design conceived as a network of interconnected objects. The true structure of the program would be hidden inside the class definition. Despite being written in an object-oriented language, there would be very little that was object-oriented about it.
- On the other hand, it's also possible to imagine a program that consists of hundreds of different kinds of objects, each with very few methods and limited functionality. Here, too, the structure of the program would be lost, this time in a maze of object connections.

Obviously, it's best to avoid either of these extremes, to keep objects large enough to take on a substantial role in the program but small enough to keep that role well-defined. The structure of the program should be easy to grasp in the pattern of object connections.

Nevertheless, the question often arises of whether to add more functionality to a class or to factor out the additional functionality and put it in an separate class definition. For example, a Faucet needs to keep track of how much water is being used over time. To do that, you could either implement the necessary methods in the Faucet class, or you could devise a generic Meter object to do the job, as suggested earlier. Each Faucet would have an outlet connecting it to a Meter, and the Meter would not interact with any object but the Faucet.

The choice often depends on your design goals. If the Meter object could be used in more than one situation, perhaps in another project entirely, it would increase the reusability of your code to factor the metering task into a separate class. If you have reason to make Faucet objects as self-contained as possible, the metering functionality could be added to the Faucet class.

It's generally better to try to for reusable code and avoid having large classes that do so many things that they can't be adapted to other situations. When objects

---

are designed as components, they become that much more reusable. What works in one system or configuration might well work in another.

Dividing functionality between different classes doesn't necessarily complicate the programming interface. If the Faucet class keeps the Meter object private, the Meter interface wouldn't have to be published for users of the Faucet class; the object would be as hidden as any other intrinsic Faucet instance variable.

### Models and Frameworks

Objects combine state and behavior, and so resemble things in the real world. Because they resemble real things, designing an object-oriented program is very much like thinking about real things—what they do, how they work, and how one thing is connected to another.

When you design an object-oriented program, you are, in effect, putting together a computer simulation of how something works. Object networks look and behave like models of real systems. An object-oriented program can be thought of as a model, even if there's no actual counterpart to it in the real world.

Each component of the model—each kind of object—is described in terms of its behavior and responsibilities and its interactions with other components. Because an object's interface lies in its methods, not its data, you can begin the design process by thinking about what a system component will do, not how it's represented in data. Once the behavior of an object is decided, the appropriate data structure can be chosen, but this is a matter of implementation, not the initial design.

For example, in the water-use program, you wouldn't begin by deciding what the Faucet data structure looked like, but what you wanted a Faucet to do—make a connection to a WaterPipe, be turned on and off, adjust the rate of flow, and so on. The design is therefore not bound from the outset by data choices. You can decide on the behavior first, and implement the data afterwards. Your choice of data structures can change over time without affecting the design.

Designing an object-oriented program doesn't necessarily entail writing great amounts of code. The reusability of class definitions means that the opportunity is great for building a program largely out of classes devised by others. It might even be possible to construct interesting programs entirely out of classes someone else defined. As the suite of class definitions grows, you have more and more reusable parts to choose from.

Reusable classes come from many sources. Development projects often yield reusable class definitions, and some enterprising developers have begun marketing them. Object-oriented programming environments typically come

with class libraries. There are well over a hundred classes in the OPENSTEP libraries. Some of these classes offer basic services (hashing, data storage, remote messaging). Others are more specific (user interface devices, video displays, a sound editor).

Typically, a group of library classes work together to define a partial program structure. These classes constitute a software framework (or kit) that can be used to build a variety of different kinds of applications. When you use a framework, you accept the program model it provides and adapt your design to it. You use the framework by:

- Initializing and arranging instances of framework classes,
- Defining subclasses of framework classes, and
- Defining new classes of your own to work with classes defined in the framework.

In each of these ways, you not only adapt your program to the framework, but you also adapt the generic framework structure to the specialized purposes of your particular application.

The framework, in essence, sets up part of a object network for your program and provides part of its class hierarchy. Your own code completes the program model started by the framework.

## Structuring the Programming Task

Object-oriented programming not only structures programs in a new way, it also helps structure the programming task.

As software tries to do more and more, and programs become bigger and more complicated, the problem of managing the task also grows. There are more pieces to fit together and more people working together to build them. The object-oriented approach offers ways of dealing with this complexity, not just in design, but also in the organization of the work.

### Collaboration

Complex software requires an extraordinary collaborative effort among people who must be individually creative, yet still make what they do fit exactly with what others are doing.

The sheer size of the effort and the number of people working on the same project at the same time in the same place can get in the way of the group's

---

ability to work cooperatively towards a common goal. In addition, collaboration is often impeded by barriers of time, space, and organization.

- Code must be maintained, improved, and used long after it's written. Programmers who collaborate on a project may not be working on it at the same time, so may not be in a position to talk things over and keep each other informed about details of the implementation.
- Even if programmers work on the same project at the same time, they may not be located in the same place. This also inhibits how closely they can work together.
- Programmers working in different groups with different priorities and different schedules often must collaborate on projects. Communication across organizational barriers isn't always easy to achieve.

The answer to these difficulties must grow out of the way programs are designed and written. It can't be imposed from the outside in the form of hierarchical management structures and strict levels of authority. These often get in the way of people's creativity, and become burdens in and of themselves. Rather, collaboration must be built into the work itself.

That's where object-oriented programming techniques can help. For example, the reusability of object-oriented code means that programmers can collaborate effectively even when they work on different projects at different times or are in different organizations, just by sharing their code in libraries. This kind of collaboration holds a great deal of promise, for it can conceivably lighten difficult tasks and bring impossible projects into the realm of possibility.

#### Organizing Object-Oriented Projects

Object-oriented programming helps restructure the programming task in ways that benefit collaboration. It helps eliminate the need to collaborate on low-level implementation details, while providing structures that facilitate collaboration at a higher level. Almost every feature of the object model, from the possibility of large-scale design to the increased reusability of code, has consequences for the way people work together.

#### Designing on a Large Scale

When programs are designed at a high level of abstraction, the division of labor is more easily conceived. It can match the division of the program on logical lines; the way a project is organized can grow out of its design.

With an object-oriented design, it's easier to keep common goals in sight, instead of losing them in the implementation, and easier for everyone to see

how the piece they're working on fits into the whole. Their collaborative efforts are therefore more likely to be on target.

### **Separating the Interface from the Implementation**

The connections between the various components of an object-oriented program are worked out early in the design process. They can be well-defined, at least for the initial phase of development, before implementation begins.

During implementation, only this interface needs to be coordinated, and most of that falls naturally out of the design. Since each class encapsulates its implementation and has its own name space, there's no need to coordinate implementation details. Collaboration is simpler when there are fewer coordination requirements.

### **Modularizing the Work**

The modularity of object-oriented programming means that the logical components of a large program can each be implemented separately. Different people can work on different classes. Each implementation task is isolated from the others.

This has benefits, not just for organizing the implementation, but for fixing problems later. Since implementations are contained within class boundaries, problems that come up are also likely to be isolated. It's easier to track down bugs when they're located in a well-defined part of the program.

Separating responsibilities by class also means that each part can be worked on by specialists. Classes can be updated periodically to optimize their performance and make the best use of new technologies. These updates don't have to be coordinated with other parts of the program. As long as the interface to an object doesn't change, improvements to its implementation can be scheduled at any time.

### **Keeping the Interface Simple**

The polymorphism of object-oriented programs yields simpler programming interfaces, since the same names and conventions can be reused in any number of different classes. The result is less to learn, a greater shared understanding of how the whole system works, and a simpler path to cooperation and collaboration.

### **Making Decisions Dynamically**

Because object-oriented programs make decisions dynamically at run time, less information needs to be supplied at compile time (in source code) to make two

---

pieces of code work together. Consequently, there's less to coordinate and less to go wrong.

### **Inheriting Generic Code**

Inheritance is a way of reusing code. If you can define your classes as specializations of more generic classes, your programming task is simplified. The design is simplified as well, since the inheritance hierarchy lays out the relationships between the different levels of implementation and makes them easier to understand.

Inheritance also increases the reusability and reliability of code. The code placed in a superclass is tested by all its subclasses. The generic class you find in a library will have been tested by other subclasses written by other developers for other applications.

### **Reusing Tested Code**

The more software you can borrow from others and incorporate in your own programs, the less you have to do yourself. There's more software to borrow in an object-oriented programming environment because the code is more reusable. Collaboration between programmers working in different places for different organizations is enhanced, while the burden of each project is eased.

Classes and frameworks from an object-oriented library can make substantial contributions to your program. When you program with the software frameworks provided by NeXT, for example, you're effectively collaborating with the programmers at NeXT; you're contracting a part of your program, often a substantial part, to them. You can concentrate on what you do best and leave other tasks to the library developer. Your projects can be prototyped faster, completed faster, with less of a collaborative challenge at your own site.

The increased reusability of object-oriented code also increases its reliability. A class taken from a library is likely to have found its way into a variety of different applications and situations. The more the code has been used, the more likely it is that problems will have been encountered and fixed. Bugs that would have seemed strange and hard to find in your program might already have been tracked down and eliminated.



*Chapter 2*

The Objective-C Language



---

This chapter describes the Objective-C language and discusses the principles of object-oriented programming as they're implemented in Objective-C. It covers all the basic features that the language adds to standard C. The next chapter continues the discussion by taking up more advanced and less commonly used language features.

Objective-C syntax is a superset of standard C syntax, and its compiler works for both C and Objective-C source code. The compiler recognizes Objective-C source files by a ".m" extension, just as it recognizes files containing only standard C syntax by a ".c" extension. The Objective-C language is fully compatible with ANSI standard C.

Objective-C can also be used as an extension to C++. At first glance, this may seem superfluous since C++ is itself an object-oriented extension of C. But C++ was designed primarily as "a better C," and not necessarily as a full-featured object-oriented language. It lacks some of the possibilities for object-oriented design that dynamic typing and dynamic binding bring to Objective-C. At the same time, it has useful language features not found in Objective-C. When you use the two languages in combination, you can assign appropriate roles to the features found in each and take advantage of what's best in both.

Because object-oriented programs postpone many decisions from compile time to run time, object-oriented languages depend on a run-time system for executing the compiled code. The run-time system for the Objective-C language is discussed in Chapter 4. This chapter and the next present the language, but touch on important elements of the run-time system as they're important for understanding language features. NeXT has modified the GNU C compiler to compile Objective-C, and NeXT provides its own run-time system.

## Objects

As the name implies, object-oriented programs are built around *objects*. An object associates data with the particular operations that can use or affect that data. In Objective-C, these operations are known as the object's *methods*; the data they affect are its *instance variables*. In essence, an object bundles a data structure (instance variables) and a group of procedures (methods) into a self-contained programming unit.

For example, if you are writing a drawing program that allows a user to create images composed of lines, circles, rectangles, text, bit-mapped images, and so forth, you might create classes for many of the basic shapes that a user will be

able to manipulate. A Rectangle object, for instance, might have instance variables that identify the position of the rectangle within the drawing along with its width and its height. Other instance variables could define the rectangle's color, whether or not it is to be filled, and a line pattern that should be used to display the rectangle. A Rectangle would have methods to set the rectangle's position, size, color, fill status, and line pattern, along with a method that causes the rectangle to display itself.

In Objective-C, an object's instance variables are internal to the object; you get access to an object's state only through the object's methods. For others to find out something about an object, there has to be a method to supply the information. For example, a Rectangle would have methods that reveal its size and its position.

Moreover, an object sees only the methods that were designed for it; it can't mistakenly perform methods intended for other types of objects. Just as a C function protects its local variables, hiding them from the rest of the program, an object hides both its instance variables and its method implementations.

id

In Objective-C, objects are identified by a distinct data type, `id`. This type is defined as a pointer to an object—in reality, a pointer to the object's data (its instance variables). Like a C function or an array, an object is identified by its address. All objects, regardless of their instance variables or methods, are of type `id`.

```
id anObject;
```

For the object-oriented constructs of Objective-C, such as method return values, `id` replaces `int` as the default data type. (For strictly C constructs, such as function return values, `int` remains the default type.)

The keyword `nil` is defined as a null object, an `id` with a value of 0. `id`, `nil`, and the other basic types of Objective-C are defined in the header file `objc.h`, which is located in the `objc` subdirectory of `/NextDeveloper/Headers`.

### Dynamic Typing

The `id` type is completely nonrestrictive. By itself, it yields no information about an object, except that it is an object.

But objects aren't all the same. A Rectangle won't have the same methods or instance variables as an object that represents a bit-mapped image. At some

---

point, a program needs to find more specific information about the objects it contains—what the object’s instance variables are, what methods it can perform, and so on. Since the `id` type designator can’t supply this information to the compiler, each object has to be able to supply it at run time.

This is possible because every object carries with it an `isa` instance variable that identifies the object’s *class*—what kind of object it is. Every `Rectangle` object would be able to tell the run-time system that it is a `Rectangle`. Every `Circle` can say that it is a `Circle`. Objects with the same behavior (methods) and the same kinds of data (instance variables) are members of the same class.

Objects are thus *dynamically typed* at run time. Whenever it needs to, the run-time system can find the exact class that an object belongs to, just by asking the object. Dynamic typing in Objective-C serves as the foundation for dynamic binding, discussed later.

The `isa` pointer also enables objects to introspect about themselves as objects. The compiler doesn’t discard much of the information it finds in source code; it arranges most of it in data structures for the run-time system to use. Through `isa`, objects can find this information and reveal it at run time. An object can, for example, say whether it has a particular method in its repertoire and what the name of its superclass is.

Object classes are discussed in more detail under “Classes” below.

It’s also possible to give the compiler information about the class of an object by statically typing it in source code using the class name. Classes are particular kinds of objects, and the class name can serve as a type name. See “Class Types” later in this chapter and “Static Options” in Chapter 3.

## Messages

To get an object to do something, you send it a *message* telling it to apply a method. In Objective-C, *message expressions* are enclosed in square brackets:

```
[receiver message]
```

The receiver is an object, and the message tells it what to do. In source code, the message is simply the name of a method and any arguments that are passed to it. When a message is sent, the run-time system selects the appropriate method from the receiver’s repertoire and invokes it.

For example, this message tells the `myRect` object to perform its `display` method, which causes the rectangle to display itself:

```
[myRect display];
```

Methods can also take arguments. The imaginary message below tells `myRect` to set its location within the window to coordinates (30.0, 50.0):

```
[myRect setOrigin:30.0 :50.0];
```

Here the method name, `setOrigin:`, has two colons, one for each of its arguments. The arguments are inserted after the colons, breaking the name apart. Colons don't have to be grouped at the end of a method name, as they are here. Usually a keyword describing the argument precedes each colon. The `setWidth:height:` method, for example, takes two arguments:

```
[myRect setWidth:10.0 height:15.0];
```

Methods that take a variable number of arguments are also possible, though they're somewhat rare. Extra arguments are separated by commas after the end of the method name. (Unlike colons, the commas aren't considered part of the name.) In the following example, the imaginary `makeGroup:` method is passed one required argument (`group`) and three that are optional:

```
[receiver makeGroup:group, memberOne, memberTwo, memberThree];
```

Like standard C functions, methods can return values. The following example sets the variable `isFilled` to YES if `myRect` is drawn as a solid rectangle, or NO if it's drawn in outline form only.

```
BOOL isFilled;  
isFilled = [myRect isFilled];
```

Note that a variable and a method can have the same name.

One message can be nested inside another. Here one rectangle is set to the color of another:

---

```
[myRect setPrimaryColor:[otherRect primaryColor]];
```

A message to `nil` also is valid, as long as the message returns an object; if it does, a message sent to `nil` will return `nil`. If the message sent to `nil` returns anything other than an object, the return value is undefined.

#### The Receiver's Instance Variables

A method has automatic access to the receiving object's instance variables. You don't need to pass them to the method as arguments. For example, the `primaryColor` method illustrated above takes no arguments, yet it can find the primary color for `otherRect` and return it. Every method assumes the receiver and its instance variables, without having to declare them as arguments.

This convention simplifies Objective-C source code. It also supports the way object-oriented programmers think about objects and messages. Messages are sent to receivers much as letters are delivered to your home. Message arguments bring information from the outside to the receiver; they don't need to bring the receiver to itself.

A method has automatic access only to the receiver's instance variables. If it requires information about a variable stored in another object, it must send a message to the object asking it to reveal the contents of the variable. The `primaryColor` and `isFilled` methods shown above are used for just this purpose.

See "Defining A Class" for more information on referring to instance variables.

#### Polymorphism

As the examples above illustrate, messages in Objective-C appear in the same syntactic positions as function calls in standard C. But, because methods "belong to" an object, messages behave differently than function calls.

In particular, an object has access only to the methods that were defined for it. It can't confuse them with methods defined for other kinds of objects, even if another object has a method with the same name. This means that two objects can respond differently to the same message. For example, each kind of object sent a `display` message could display itself in a unique way. A `Circle` and a `Rectangle` would respond differently to identical instructions to track the cursor.

This feature, referred to as *polymorphism*, plays a significant role in the design of object-oriented programs. Together with dynamic binding, it permits you to write code that might apply to any number of different kinds of objects, without your having to choose at the time you write the code what kinds of objects they

might be. They might even be objects that will be developed later, by other programmers working on other projects. If you write code that sends a `display` message to an `id` variable, any object that has a `display` method is a potential receiver.

### Dynamic Binding

A crucial difference between function calls and messages is that a function and its arguments are joined together in the compiled code, but a message and a receiving object aren't united until the program is running and the message is sent. Therefore, the exact method that will be invoked to respond to a message can only be determined at run time, not when the code is compiled.

The precise method that a message invokes depends on the receiver. Different receivers may have different method implementations for the same method name (polymorphism). For the compiler to find the right method implementation for a message, it would have to know what kind of object the receiver is—what class it belongs to. This is information the receiver is able to reveal at run time when it receives a message (dynamic typing), but it's not available from the type declarations found in source code.

The selection of a method implementation happens at run time. When a message is sent, a run-time messaging routine looks at the receiver and at the method named in the message. It locates the receiver's implementation of a method matching the name, "calls" the method, and passes it a pointer to the receiver's instance variables. (For more on this routine, see "How Messaging Works" below.)

The method name in a message thus serves to "select" a method implementation. For this reason, method names in messages are often referred to as *selectors*.

This *dynamic binding* of methods to messages works hand-in-hand with polymorphism to give object-oriented programming much of its flexibility and power. Since each object can have its own version of a method, a program can achieve a variety of results, not by varying the message itself, but by varying just the object that receives the message. This can be done as the program runs; receivers can be decided "on the fly" and can be made dependent on external factors such as user actions.

When executing code based upon the Application Kit, for example, users determine which objects receive messages from menu commands like Cut, Copy, and Paste. The message goes to whatever object controls the current selection. An object that displays editable text would react to a `copy` message differently than an object that displays scanned images. An object that

---

represents a set of shapes would respond differently than a Rectangle. Since messages don't select methods (methods aren't bound to messages) until run time, these differences are isolated in the methods that respond to the message. The code that sends the message doesn't have to be concerned with them; it doesn't even have to enumerate the possibilities. Each application can invent its own objects that respond in their own way to copy messages.

Objective-C takes dynamic binding one step further and allows even the message that's sent (the method selector) to be a variable that's determined at run time. This is discussed in the section on "How Messaging Works."

## Classes

An object-oriented program is typically built from a variety of objects. A program based on the OpenStep software frameworks might use NSMatrix objects, NSWindow objects, NSDictionary objects, NSFont objects, NSText objects, and many others. Programs often use more than one object of the same kind or *class*—several NSArrays or NSWindows, for example.

In Objective-C, you define objects by defining their class. The class definition is a prototype for a kind of object; it declares the instance variables that become part of every member of the class, and it defines a set of methods that all objects in the class can use.

The compiler creates just one accessible object for each class, a *class object* that knows how to build new objects belonging to the class. (For this reason it's traditionally called a "factory object.") The class object is the compiled version of the class; the objects it builds are *instances* of the class. The objects that will do the main work of your program are instances created by the class object at run time.

All instances of a class have access to the same set of methods, and they all have a set of instance variables cut from the same mold. Each object gets its own instance variables, but the methods are shared.

By convention, class names begin with an uppercase letter (such as "Rectangle"); the names of instances typically begin with a lowercase letter (such as "myRect").

### Inheritance

Class definitions are additive; each new class that you define is based on another class through which it *inherits* methods and instance variables. The new class

simply adds to or modifies what it inherits. It doesn't need to duplicate inherited code.

Inheritance links all classes together in a hierarchical tree with a single class at its root. When writing code that is based upon the Foundation framework, that root class is typically `NSObject`. Every class (except a root class) has a *superclass* one step nearer the root, and any class (including a root class) can be the superclass for any number of *subclasses* one step farther from the root. The figure below illustrates the hierarchy for a few of the classes used in the drawing program.

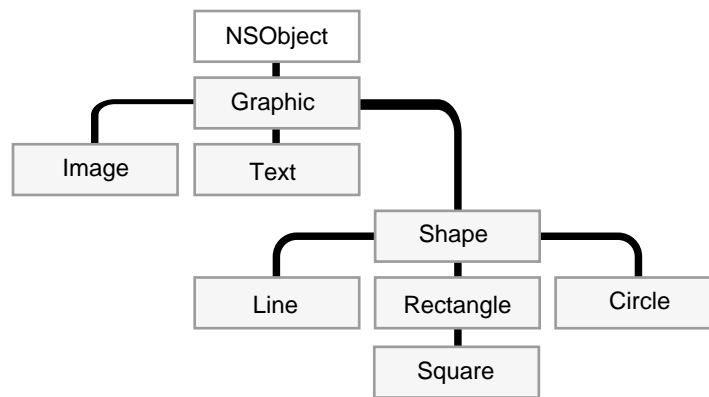

This figure shows that the `Square` class is a subclass of the `Rectangle` class, the `Rectangle` class is a subclass of `Shape`, `Shape` is a subclass of `Graphic`, and `Graphic` is a subclass of `NSObject`. Inheritance is cumulative. So a `Square` object has the methods and instance variables defined for `Rectangle`, `Shape`, `Graphic`, and `NSObject`, as well as those defined specifically for `Square`. This is simply to say that a `Square` object isn't only a `Square`, it's also a `Rectangle`, a `Shape`, a `Graphic`, and an `NSObject`.

Every class but `NSObject` can thus be seen as a specialization or an adaptation of another class. Each successive subclass further modifies the cumulative total of what's inherited. The `Square` class defines only the minimum needed to turn a `Rectangle` into a `Square`.

When you define a class, you link it to the hierarchy by declaring its superclass; every class you create must be the subclass of another class (unless you define a new root class). Plenty of potential superclasses are available. `OPENSTEP` includes the `NSObject` class and several software frameworks containing definitions for more than 125 additional classes. Some are classes that you can use “off the shelf”—incorporate into your program as is. Others you might want to adapt to your own needs by defining a subclass.

---

Some framework classes define almost everything you need, but leave some specifics to be implemented in a subclass. You can thus create very sophisticated objects by writing only a small amount of code, and reusing work done by the programmers of the framework.

### **The NSObject Class**

NSObject, being a root class, doesn't have a superclass. In OpenStep, it's in the inheritance path for every other class. That's because it defines the basic framework for Objective-C objects and object interactions. It imparts to the classes and instances that inherit from it the ability to behave as objects and cooperate with the run-time system.

A class that doesn't need to inherit any special behavior from another class is nevertheless made a subclass of the NSObject class. Instances of the class must at least have the ability to behave like Objective-C objects at run time. Inheriting this ability from the NSObject class is much simpler and much more reliable than reinventing it in a new class definition.

**Note:** Implementing a new root class is a delicate task and one with many hidden hazards. The class must duplicate much of what the NSObject class does, such as allocate instances, connect them to their class, and identify them to the run-time system. It's strongly recommended that you use the NSObject class provided with OpenStep as the root class. This manual doesn't explain all the ins and outs that you would need to know to replace it.

### **Inheriting Instance Variables**

When a class object creates a new instance, the new object contains not only the instance variables that were defined for its class, but also the instance variables defined for its superclass, and for its superclass's superclass, all the way back to the root class. Thus, the isa instance variable defined in the NSObject class becomes part of every object. isa connects each object to its class.

The figure below shows some of the instance variables that could be defined for a particular implementation of Rectangle, and where they might come from. Note that the variables that make the object a Rectangle are added to the ones that make it a Shape, and the ones that make it a Shape are added to the ones that make it a Graphic, and so on.

Class	isa;	—	declared in NSObject
NSPoint	origin;	—	declared in Graphic
NSColor	*primaryColor;	}	declared in Shape
Pattern	linePattern;		
...		}	declared in Rectangle
float	width;		
float	height;		
BOOL	filled;		
NSColor	*fillColor;		
...			

A class doesn't have to declare instance variables. It can simply define new methods and rely on the instance variables it inherits, if it needs any instance variables at all. For instance, Square might not declare any new instance variables of its own.

### Inheriting Methods

An object has access not only to the methods that were defined for its class, but also to methods defined for its superclass, and for its superclass's superclass, all the way back to the root of the hierarchy. For instance, a Square object can use methods defined in the Rectangle, Shape, Graphic, and NSObject classes as well as methods defined in its own class.

Any new class you define in your program can therefore make use of the code written for all the classes above it in the hierarchy. This type of inheritance is a major benefit of object-oriented programming. When you use one of the object-oriented frameworks provided by OPENSTEP, your programs can take advantage of all the basic functionality coded into the framework classes. You have to add only the code that customizes the framework to your application.

Class objects also inherit from the classes above them in the hierarchy. But because they don't have instance variables (only instances do), they inherit only methods.

### Overriding One Method With Another

There's one useful exception to inheritance: When you define a new class, you can implement a new method with the same name as one defined in a class farther up the hierarchy. The new method overrides the original; instances of the new class will perform it rather than the original, and subclasses of the new class will inherit it rather than the original.

For example, Graphic defines a `display` method that Rectangle overrides by defining its own version of `display`. The Graphic method is available to all kinds

---

of objects that inherit from the Graphic class—but not to Rectangle objects, which instead perform the Rectangle version of `display`.

Although overriding a method blocks the original version from being inherited, other methods defined in the new class can skip over the redefined method and find the original (see “Messages to self and super,” below, to learn how).

A redefined method can also incorporate the very method it overrides. When it does, the new method serves only to refine or modify the method it overrides, rather than replace it outright. When several classes in the hierarchy define the same method, but each new version incorporates the version it overrides, the implementation of the method is effectively spread over all the classes.

Although a subclass can override inherited methods, it can’t override inherited instance variables. Since an object has memory allocated for every instance variable it inherits, you can’t override an inherited variable by declaring a new one with the same name. If you try, the compiler will complain.

### **Abstract Classes**

Some classes are designed only so that other classes can inherit from them. These *abstract classes* group methods and instance variables that will be used by a number of different subclasses into a common definition. The abstract class is incomplete by itself, but contains useful code that reduces the implementation burden of its subclasses.

The `NSObject` class is the prime example of an abstract class. Although programs often define `NSObject` subclasses and use instances belonging to the subclasses, they never use instances belonging directly to the `NSObject` class. An `NSObject` instance wouldn’t be good for anything; it would be a generic object with the ability to do nothing in particular.

Abstract classes often contain code that helps define the structure of an application. When you create subclasses of these classes, instances of your new classes fit effortlessly into the application structure and work automatically with other objects.

(Because abstract classes must have subclasses, they’re sometimes also called *abstract superclasses*.)

### **Class Types**

A class definition is a specification for a kind of object. The class, in effect, defines a data type. The type is based not just on the data structure the class defines (instance variables), but also on the behavior included in the definition (methods).

A class name can appear in source code wherever a type specifier is permitted in C—for example, as an argument to the `sizeof` operator:

```
int i = sizeof(Rectangle);
```

### Static Typing

You can use a class name in place of `id` to designate an object's type:

```
Rectangle *myRect;
```

Because this way of declaring an object type gives the compiler information about what kind of object it is, it's known as *static typing*. Just as `id` is defined as a pointer to an object, objects are statically typed as pointers to a class. Objects are always typed by a pointer. Static typing makes the pointer explicit; `id` hides it.

Static typing permits the compiler to do some type checking—for example, to warn if an object receives a message that it appears not to be able to respond to—and to loosen some restrictions that apply to objects generically typed `id`. In addition, it can make your intentions clearer to others who read your source code. However, it doesn't defeat dynamic binding or alter the dynamic determination of a receiver's class at run time.

An object can be statically typed to its own class or to any class that it inherits from. For example, since inheritance makes a `Rectangle` a kind of `Graphic`, a `Rectangle` instance could be statically typed to the `Graphic` class:

```
Graphic *myRect;
```

This is possible because a `Rectangle` is a `Graphic`. It's more than a `Graphic` since it also has the instance variables and method capabilities of a `Shape` and a `Rectangle`, but it's a `Graphic` nonetheless. For purposes of type checking, the compiler will consider `myRect` to be an `Graphic`, but at run time it will be treated as a `Rectangle`.

See “Static Options” in the next chapter for more on static typing and its benefits.

---

## Type Introspection

Instances can reveal their types at run time. The `isMemberOfClass:` method, defined in the `NSObject` class, checks whether the receiver is an instance of a particular class:

```
if ( [anObject isMemberOfClass:someClass] )  
    . . .
```

The `isKindOfClass:` method, also defined in the `NSObject` class, checks more generally whether the receiver inherits from or is a member of a particular class (whether it has the class in its inheritance path):

```
if ( [anObject isKindOfClass:someClass] )  
    . . .
```

The set of classes for which `isKindOfClass:` returns YES is the same set to which the receiver can be statically typed.

Introspection isn't limited to type information. Later sections of this chapter discuss methods that return the class object, report whether an object can respond to a message, and reveal other information.

See the `NSObject` class specification in the *Foundation Framework Reference* for more on `isKindOfClass:`, `isMemberOfClass:`, and related methods.

## Class Objects

A class definition contains various kinds of information, much of it about instances of the class:

- The name of the class and its superclass
- A template describing a set of instance variables
- The declaration of method names and their return and argument types
- The method implementations

This information is compiled and recorded in data structures made available to the run-time system. The compiler creates just one object, a *class object*, to represent the class. The class object has access to all the information about the class, which means mainly information about what instances of the class are like. It's able to produce new instances according to the plan put forward in the class definition.

Although a class object keeps the prototype of a class instance, it's not an instance itself. It has no instance variables of its own and it can't perform methods intended for instances of the class. However, a class definition can include methods intended specifically for the class object—*class methods* as opposed to *instance methods*. A class object inherits class methods from the classes above it in the hierarchy, just as instances inherit instance methods.

In source code, the class object is represented by the class name. In the following example, the Rectangle class returns the class version number using a method inherited from the NSObject class:

```
int versionNumber = [Rectangle version];
```

However, the class name stands for the class object only as the receiver in a message expression. Elsewhere, you need to ask an instance or the class to return the class id. Both respond to a class message:

```
id aClass = [anObject class];  
id rectClass = [Rectangle class];
```

As these examples show, class objects can, like all other objects, be typed id. But class objects can also be more specifically typed to the Class data type:

```
Class aClass = [anObject class];  
Class rectClass = [Rectangle class];
```

All class objects are of type Class. Using this type name for a class is equivalent to using the class name to statically type an instance.

Class objects are thus full-fledged objects that can be dynamically typed, receive messages, and inherit methods from other classes. They're special only in that they're created by the compiler, lack data structures (instance variables) of their own other than those built from the class definition, and are the agents for producing instances at run time.

**Note:** The compiler also builds a “meta-class object” for each class. It describes the class object just as the class object describes instances of the class. But while you can send messages to instances and to the class object, the meta-class object is used only internally by the run-time system.

---

## Creating Instances

A principal function of a class object is to create new instances. This code tells the `Rectangle` class to create a new `Rectangle` instance and assign it to the `myRect` variable:

```
id myRect;  
myRect = [Rectangle alloc];
```

The `alloc` method dynamically allocates memory for the new object's instance variables and initializes them all to 0—all, that is, except the `isa` variable that connects the new instance to its class. For an object to be useful, it generally needs to be more completely initialized. That's the function of an `init` method. Initialization typically follows immediately after allocation:

```
myRect = [[Rectangle alloc] init];
```

This line of code, or one like it, would be necessary before `myRect` could receive any of the messages that were illustrated in previous examples in this chapter. The `alloc` method returns a new instance and that instance performs an `init` method to set its initial state. Every class object has at least one method (like `alloc`) that enables it to produce new objects, and every instance has at least one method (like `init`) that prepares it for use. Initialization methods often take arguments to allow particular values to be passed and have keywords to label the arguments (`initWithPosition:size:`, for example, is a method that might initialize a new `Rectangle` instance), but they all begin with “`init`”.

## Customization With Class Objects

It's not just a whim of the Objective-C language that classes are treated as objects. It's a choice that has intended, and sometimes surprising, benefits for design. It's possible, for example, to customize an object with a class, where the class belongs to an open-ended set. In the Application Kit, for example, an `NSMatrix` object can be customized with a particular kind of `NSCell`.

An `NSMatrix` can take responsibility for creating the individual objects that represent its cells. It can do this when the `NSMatrix` is first initialized and later when new cells are needed. The visible matrix that an `NSMatrix` object draws on-screen can grow and shrink at run time, perhaps in response to user actions. When it grows, the `NSMatrix` needs to be able to produce new objects to fill the new slots that are added.

But what kind of objects should they be? Each `NSMatrix` displays just one kind of `NSCell`, but there are many different kinds. The inheritance hierarchy in the following figure shows some of those provided by the Application Kit. All inherit from the generic `NSCell` class:

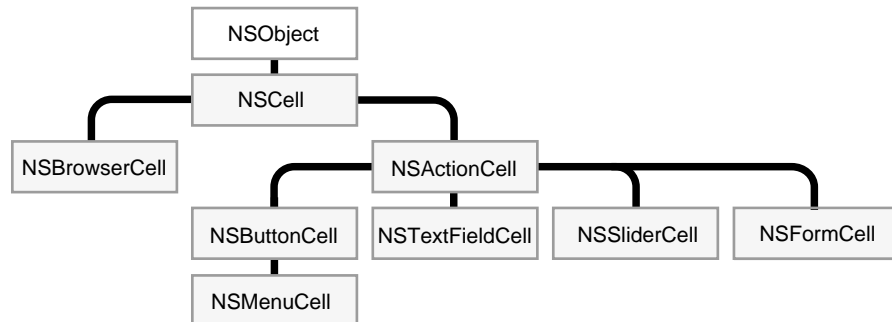

When an `NSMatrix` creates new `NSCell` objects, should they be `NSButtonCells` to display a bank of buttons or switches, `NSTextFieldCells` to display fields where the user can enter and edit text, or some other kind of `NSCell`? The `NSMatrix` must allow for any kind of `NSCell`, even types that haven't been invented yet.

One solution to this problem would be to define the `NSMatrix` class as an abstract class and require everyone who uses it to declare a subclass and implement the methods that produce new cells. Because they would be implementing the methods, users of the class could be sure that the objects they created were of the right type.

But this requires others to do work that ought to be done in the `NSMatrix` class, and it unnecessarily proliferates the number of classes. Since an application might need more than one kind of `NSMatrix`, each with a different kind of `NSCell`, it could become cluttered with `NSMatrix` subclasses. Every time you invented a new kind of `NSCell`, you'd also have to define a new kind of `NSMatrix`. Moreover, programmers on different projects would be writing virtually identical code to do the same job, all to make up for `NSMatrix`'s failure to do it.

A better solution, the solution the `NSMatrix` class actually adopts, is to allow `NSMatrix` instances to be initialized with a kind of `NSCell`—with a class object. It defines a `setCellClass:` method that passes the class object for the kind of `NSCell` object an `NSMatrix` should use to fill empty slots:

```
[myMatrix setCellClass:[NSButtonCell class]];
```

---

The `NSMatrix` uses the class object to produce new cells when it's first initialized and whenever it's resized to contain more cells. This kind of customization would be impossible if classes weren't objects that could be passed in messages and assigned to variables.

### Variables and Class Objects

When you define a new class of objects, you can decide what instance variables they should have. Every instance of the class will have its own copy of all the variables you declare; each object controls its own data.

However, you can't prescribe variables for the class object; there are no "class variable" counterparts to instance variables. Only internal data structures, initialized from the class definition, are provided for the class. The class object also has no access to the instance variables of any instances; it can't initialize, read, or alter them.

Therefore, for all the instances of a class to share data, an external variable of some sort is required. Some classes declare static variables and provide class methods to manage them. (Declaring a variable `static` in the same file as the class definition limits its scope to just the class—and to just the part of the class that's implemented in the file. Unlike instance variables, static variables can't be inherited by subclasses.)

Static variables help give the class object more functionality than just that of a "factory" producing instances; it can approach being a complete and versatile object in its own right. A class object can be used to coordinate the instances it creates, dispense instances from lists of objects already created, or manage other processes essential to the application. In the limiting case, when you need only one object of a particular class, you can put all the object's state into static variables and use only class methods. This saves the step of allocating and initializing an instance.

**Note:** It would also be possible to use external variables that weren't declared `static`, but the limited scope of static variables better serves the purpose of encapsulating data into separate objects.

### Initializing a Class Object

If a class object is to be used for anything besides allocating instances, it may need to be initialized just as an instance is. Although programs don't allocate class objects, Objective-C does provide a way for programs to initialize them.

The run-time system sends an `initialize` message to every class object before the class receives any other messages. This gives the class a chance to set up its run-time environment before it's used. If no initialization is required, you don't need

to write an `initialize` method to respond to the message; the `NSObject` class defines an empty version that your class inherits.

If a class makes use of static or global variables, the `initialize` method is a good place to set their initial values. For example, if a class maintains an array of instances, the `initialize` method could set up the array and even allocate one or two default instances to have them ready.

Note that since `initialize` is inherited, it may be called multiple times on behalf of subclasses.

### Methods of the Root Class

All objects, classes and instances alike, need an interface to the run-time system. Both class objects and instances should be able to introspect about their abilities and to report their place in the inheritance hierarchy. It's the province of the `NSObject` class to provide this interface.

So that `NSObject`'s methods won't all have to be implemented twice—once to provide a run-time interface for instances and again to duplicate that interface for class objects—class objects are given special dispensation to perform instance methods defined in the root class. When a class object receives a message that it can't respond to with a class method, the run-time system will see if there's a root instance method that can respond. The only instance methods that a class object can perform are those defined in the root class, and only if there's no class method that can do the job.

For more on this peculiar ability of class objects to perform root instance methods, see the `NSObject` class specification in the *Foundation Framework Reference*.

### Class Names in Source Code

In source code, class names can be used in only two very different contexts. These contexts reflect the dual role of a class as a data type and as an object:

- The class name can be used as a type name for a kind of object. For example:

```
Rectangle *anObject;  
anObject = [[Rectangle alloc] init];
```

Here `anObject` is statically typed to be a `Rectangle`. The compiler will expect it to have the data structure of a `Rectangle` instance and the instance methods defined and inherited by the `Rectangle` class. Static typing enables

---

the compiler to do better type checking and makes source code more self-documenting. See “Static Options” in the next chapter for details.

Only instances can be statically typed; class objects can't be, since they aren't members of a class, but rather belong to the Class data type.

- As the receiver in a message expression, the class name refers to the class object. This usage was illustrated in several of the examples above. The class name can stand for the class object only as a message receiver. In any other context, you must ask the class object to reveal its id (by sending it a class message). The example below passes the Rectangle class as an argument in an `isKindOfClass:` message.

```
if ( [anObject isKindOfClass:[Rectangle class]] )
    . . .
```

It would have been illegal to simply use the name “Rectangle” as the argument. The class name can only be a receiver.

If you don't know the class name at compile time but have it as a string at run time, `objc_lookupClass()` will return the class object:

```
char *aBuffer;
. . .
if ( [anObject isKindOfClass:objc_lookupClass(aBuffer)] )
    . . .
```

This function returns `nil` if the string it's passed is not a valid class name.

Class names compete in the same name space as variables and functions. A class and a global variable can't have the same name. Class names are about the only names with global visibility in Objective-C.

## Defining A Class

Much of object-oriented programming consists of writing the code for new objects—defining new classes. In Objective-C, classes are defined in two parts:

- An *interface* that declares the methods and instance variables of the class and names its superclass

- An *implementation* that actually defines the class (contains the code that implements its methods)

Although the compiler doesn't require it, the interface and implementation are usually separated into two different files. The interface file must be made available to anyone who uses the class. You generally wouldn't want to distribute the implementation file that widely; users don't need source code for the implementation.

A single file can declare or implement more than one class. Nevertheless, it's customary to have a separate interface file for each class, if not also a separate implementation file. Keeping class interfaces separate better reflects their status as independent entities.

Interface and implementation files typically are named after the class. The implementation file has a ".m" suffix, indicating that it contains Objective-C source code. The interface file can be assigned any other extension. Because it's included in other source files, the interface file usually has the ".h" suffix typical of header files. For example, the Rectangle class would be declared in `Rectangle.h` and defined in `Rectangle.m`.

Separating an object's interface from its implementation fits well with the design of object-oriented programs. An object is a self-contained entity that can be viewed from the outside almost as a "black box." Once you've determined how an object will interact with other elements in your program—that is, once you've declared its interface—you can freely alter its implementation without affecting any other part of the application.

### The Interface

The declaration of a class interface begins with the compiler directive `@interface` and ends with the directive `@end`. (All Objective-C directives to the compiler begin with "@".)

```
@interface ClassName : ItsSuperclass
{
    instance variable declarations
}
method declarations
@end
```

The first line of the declaration presents the new class name and links it to its superclass. The superclass defines the position of the new class in the inheritance hierarchy, as discussed under "Inheritance" above. If the colon and

---

superclass name are omitted, the new class is declared as a root class, a rival to the NSObject class.

Following the class declaration, braces enclose declarations of *instance variables*, the data structures that will be part of each instance of the class. Here's a partial list of instance variables that might be declared in the Rectangle class:

```
float width
float height;
BOOL filled;
NSColor *fillColor;
```

Methods for the class are declared next, after the braces enclosing instance variables and before the end of the class declaration. The names of methods that can be used by class objects, *class methods*, are preceded by a plus sign:

```
+ alloc;
```

The methods that instances of a class can use, *instance methods*, are marked with a minus sign:

```
- (void)display;
```

Although it's not a common practice, you can define a class method and an instance method with the same name. A method can also have the same name as an instance variable. This is more common, especially if the method returns the value in the variable. For example, Circle has a *radius* method that could match a *radius* instance variable.

Method return types are declared using the standard C syntax for casting one type to another:

```
- (float)radius;
```

Argument types are declared in the same way:

```
- (void)setRadius:(float)aRadius;
```

If a return or argument type isn't explicitly declared, it's assumed to be the default type for methods and messages—an `id`. The `alloc` method illustrated above returns `id`.

When there's more than one argument, they're declared within the method name after the colons. Arguments break the name apart in the declaration, just as in a message. For example:

```
- (void)setWidth:(float)width height:(float)height;
```

Methods that take a variable number of arguments declare them using a comma and an ellipsis, just as a function would:

```
- makeGroup:group, ...;
```

### Importing the Interface

The interface file must be included in any source module that depends on the class interface—that includes any module that creates an instance of the class, sends a message to invoke a method declared for the class, or mentions an instance variable declared in the class. The interface is usually included with the `#import` directive:

```
#import "Rectangle.h"
```

This directive is identical to `#include`, except that it makes sure that the same file is never included more than once. It's therefore preferred and is used in place of `#include` in code examples throughout NeXT documentation.

To reflect the fact that a class definition builds on the definitions of inherited classes, an interface file begins by importing the interface for its superclass:

```
#import "ItsSuperclass.h"

@interface ClassName : ItsSuperclass
{
    instance variable declarations
}
method declarations
@end
```

---

This convention means that every interface file includes, indirectly, the interface files for all inherited classes. When a source module imports a class interface, it gets interfaces for the entire inheritance hierarchy that the class is built upon.

Note that if there is a “precomp”—a precompiled header—that supports the superclass, you may prefer to import the precomp instead.

### Referring to Other Classes

An interface file declares a class and, by importing its superclass, implicitly contains declarations for all inherited classes, from NSObject on down through its superclass. If the interface mentions classes not in this hierarchy, it must import them explicitly or declare them with the @class directive:

```
@class Rectangle, Circle;
```

This directive simply informs the compiler that “Rectangle” and “Circle” are class names. It doesn’t import their interface files.

An interface file mentions class names when it statically types instance variables, return values, and arguments. For example, this declaration

```
- (void)setPrimaryColor:(NSColor *)aColor;
```

mentions the NSColor class.

Since declarations like this simply use the class name as a type and don’t depend on any details of the class interface (its methods and instance variables), the @class directive gives the compiler sufficient forewarning of what to expect. However, where the interface to a class is actually used (instances created, messages sent), the class interface must be imported. Typically, an interface file uses @class to declare classes, and the corresponding implementation file imports their interfaces (since it will need to create instances of those classes or send them messages).

The @class directive minimizes the amount of code seen by the compiler and linker, and is therefore the simplest way to give a forward declaration of a class name. Being simple, it avoids potential problems that may come with importing files that import still other files. For example, if one class declares a statically typed instance variable of another class, and their two interface files import each other, neither class may compile correctly.

### The Role of the Interface

The purpose of the interface file is to declare the new class to other source modules (and to other programmers). It contains all the information they need to work with the class (programmers might also appreciate a little documentation).

- The interface file tells users how the class is connected into the inheritance hierarchy and what other classes—inherited or simply referred to somewhere in the class—are needed.
- The interface file also lets the compiler know what instance variables an object contains and programmers know what variables their subclasses will inherit. Although instance variables are most naturally viewed as a matter of the implementation of a class rather than its interface, they must nevertheless be declared in the interface file. This is because the compiler must be aware of the structure of an object where it's used, not just where it's defined. As a programmer, however, you can generally ignore the instance variables of the classes you use, except when defining a subclass.
- Finally, through its list of method declarations, the interface file lets other modules know what messages can be sent to the class object and instances of the class. Every method that can be used outside the class definition is declared in the interface file; methods that are internal to the class implementation can be omitted.

### The Implementation

The definition of a class is structured very much like its declaration. It begins with an `@implementation` directive and ends with `@end`:

```
@implementation ClassName : ItsSuperclass
{
    instance variable declarations
}
method definitions
@end
```

However, every implementation file must import its own interface. For example, `Rectangle.m` imports `Rectangle.h`. Because the implementation doesn't need to repeat any of the declarations it imports, it can safely omit:

- The name of the superclass
- The declarations of instance variables

---

This simplifies the implementation and makes it mainly devoted to method definitions:

```
#import "ClassName.h"

@implementation ClassName
method definitions
@end
```

Methods for a class are defined, like C functions, within a pair of braces. Before the braces, they're declared in the same manner as in the interface file, but without the semicolon. For example:

```
+ alloc
{
    . . .
}

- (BOOL)isfilled
{
    . . .
}

- (void)setFilled:(BOOL)flag
{
    . . .
}
```

Methods that take a variable number of arguments handle them just as a function would:

```
#import <stdarg.h>

. . .

- getGroup:group, ...
{
    va_list ap;
    va_start(ap, group);
    . . .
}
```

### Referring to Instance Variables

By default, the definition of an instance method has all the instance variables of the object within its scope. It can refer to them simply by name. Although the

compiler creates the equivalent of C structures to store instance variables, the exact nature of the structure is hidden. You don't need either of the structure operators ('.' or '->') to refer to an object's data. For example, the following method definition refers to the receiver's tag instance variable:

```
- (void)setFilled:(BOOL)flag
{
    filled = flag;
    . . .
}
```

Neither the receiving object nor its `filled` instance variable is declared as an argument to this method, yet the instance variable falls within its scope. This simplification of method syntax is a significant shorthand in the writing of Objective-C code.

When the instance variable belongs to an object that's not the receiver, the object's type must be made explicit to the compiler through static typing. In referring to the instance variable of a statically typed object, the structure pointer operator ('->') is used.

Suppose, for example, that the `Sibling` class declares a statically typed object, `twin`, as an instance variable:

```
@interface Sibling : NSObject
{
    Sibling *twin;
    int gender;
    struct features *appearance;
}
```

As long as the instance variables of the statically typed object are within the scope of the class (as they are here because `twin` is typed to the same class), a `Sibling` method can set them directly:

---

```
- makeIdenticalTwin
{
    if ( !twin ) {
        twin = [[Sibling alloc] init];
        twin->gender = gender;
        twin->appearance = appearance;
    }
    return twin;
}
```

### The Scope of Instance Variables

Although they're declared in the class interface, instance variables are more a matter of the way a class is implemented than of the way it's used. An object's interface lies in its methods, not in its internal data structures.

Often there's a one-to-one correspondence between a method and an instance variable, as in the following example:

```
- (BOOL)isFilled
{
    return filled;
}
```

But this need not be the case. Some methods might return information not stored in instance variables, and some instance variables might store information that an object is unwilling to reveal.

As a class is revised from time to time, the choice of instance variables may change, even though the methods it declares remain the same. As long as messages are the vehicle for interacting with instances of the class, these changes won't really affect its interface.

To enforce the ability of an object to hide its data, the compiler limits the scope of instance variables—that is, limits their visibility within the program. But to provide flexibility, it also lets you explicitly set the scope at three different levels. Each level is marked by a compiler directive:

Directive	Meaning
@private	The instance variable is accessible only within the class that declares it.
@protected	The instance variable is accessible within the class that declares it and within classes that inherit it.
@public	The instance variable is accessible everywhere.

This is illustrated in the following figure.

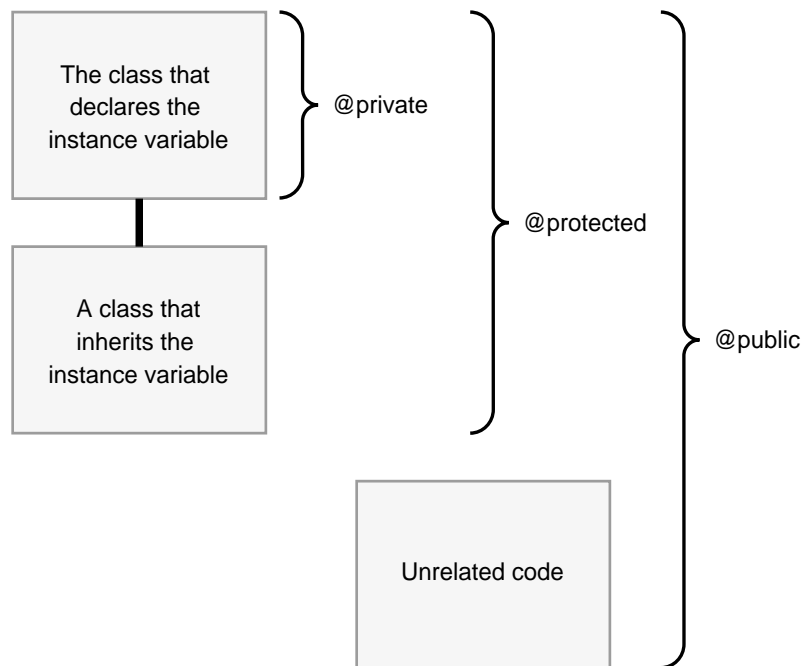

A directive applies to all the instance variables listed after it, up to the next directive or the end of the list. In the following example, the `age` and `evaluation` instance variables are private, `name`, `job`, and `wage` are protected, and `boss` is public.

---

```
@interface Worker : NSObject
{
    char *name;
@private
    int age;
    char *evaluation;
@protected
    id job;
    float wage;
@public
    id boss;
}
```

By default, all unmarked instance variables (like `name` above) are `@protected`.

All instance variables that a class declares, no matter how they're marked, are within the scope of the class definition. For example, a class that declares a `job` instance variable, such as the `Worker` class shown above, can refer to it in a method definition:

```
- promoteTo:newPosition
{
    id old = job;
    job = newPosition;
    return old;
}
```

Obviously, if a class couldn't access its own instance variables, the instance variables would be of no use whatsoever.

Normally, a class also has access to the instance variables it inherits. The ability to refer to an instance variable is usually inherited along with the variable. It makes sense for classes to have their entire data structures within their scope, especially if you think of a class definition as merely an elaboration of the classes it inherits from. The `promoteTo:` method illustrated above could just as well have been defined in any class that inherits the `job` instance variable from the `Worker` class.

However, there are reasons why you might want to restrict inheriting classes from accessing an instance variable:

- Once a subclass accesses an inherited instance variable, the class that declares the variable is tied to that part of its implementation. In later versions, it can't eliminate the variable or alter the role it plays without inadvertently breaking the subclass.

- Moreover, if a subclass accesses an inherited instance variable and alters its value, it may inadvertently introduce bugs in the class that declares the variable, especially if the variable is involved in class-internal dependencies.

To limit an instance variable's scope to just the class that declares it, you must mark it `@private`.

At the other extreme, marking a variable `@public` makes it generally available, even outside of class definitions that inherit or declare the variable. Normally, to get information stored in an instance variable, other objects must send a message requesting it. However, a public instance variable can be accessed anywhere as if it were a field in a C structure.

```
Worker *ceo = [[Worker alloc] init];
ceo->boss = nil;
```

Note that the object must be statically typed.

Marking instance variables `@public` defeats the ability of an object to hide its data. It runs counter to a fundamental principle of object-oriented programming—the encapsulation of data within objects where it's protected from view and inadvertent error. Public instance variables should therefore be avoided except in extraordinary cases.

## How Messaging Works

In Objective-C, messages aren't bound to method implementations until run time. The compiler converts a message expression,

```
[receiver message]
```

into a call on a messaging function, `objc_msgSend()`. This function takes the receiver and the name of the method mentioned in the message—that is, the *method selector*—as its two principal arguments:

```
objc_msgSend(receiver, selector)
```

Any arguments passed in the message are also handed to `objc_msgSend()`:

---

```
objc_msgSend(receiver, selector, arg1, arg2, . . .)
```

The messaging function does everything necessary for dynamic binding:

- It first finds the procedure (method implementation) that the selector refers to. Since the same method can be implemented differently by different classes, the precise procedure that it finds depends on the class of the receiver.
- It then calls the procedure, passing it the receiving object (a pointer to its data), along with any arguments that were specified for the method.
- Finally, it passes on the return value of the procedure as its own return value.

**Note:** The compiler generates calls to the messaging function. You should never call it directly in the code you write.

The key to messaging lies in the structures that the compiler builds for each class and object. Every class structure includes these two essential elements:

- A pointer to the superclass.
- A class *dispatch table*. This table has entries that associate method selectors with the class-specific addresses of the methods they identify. The selector for the `setOrigin::` method is associated with the address of (the procedure that implements) `setOrigin::`, the selector for the `display` method is associated with `display`'s address, and so on.

When a new object is created, memory for it is allocated, and its instance variables are initialized. First among the object's variables is a pointer to its class structure. This pointer, called `isa`, gives the object access to its class and, through the class, to all the classes it inherits from.

**Note:** While not strictly a part of the language, the `isa` pointer is required for an object to work with NeXT's run-time system. An object needs to be "equivalent" to a `struct objc_object` (defined in `objc/objc.h`) in whatever fields the structure defines. However, you will rarely if ever need to create your own root object, and objects that inherit from `NSObject` or `NSProxy` automatically have the `isa` variable.

These elements of class and object structure are illustrated in the following figure.

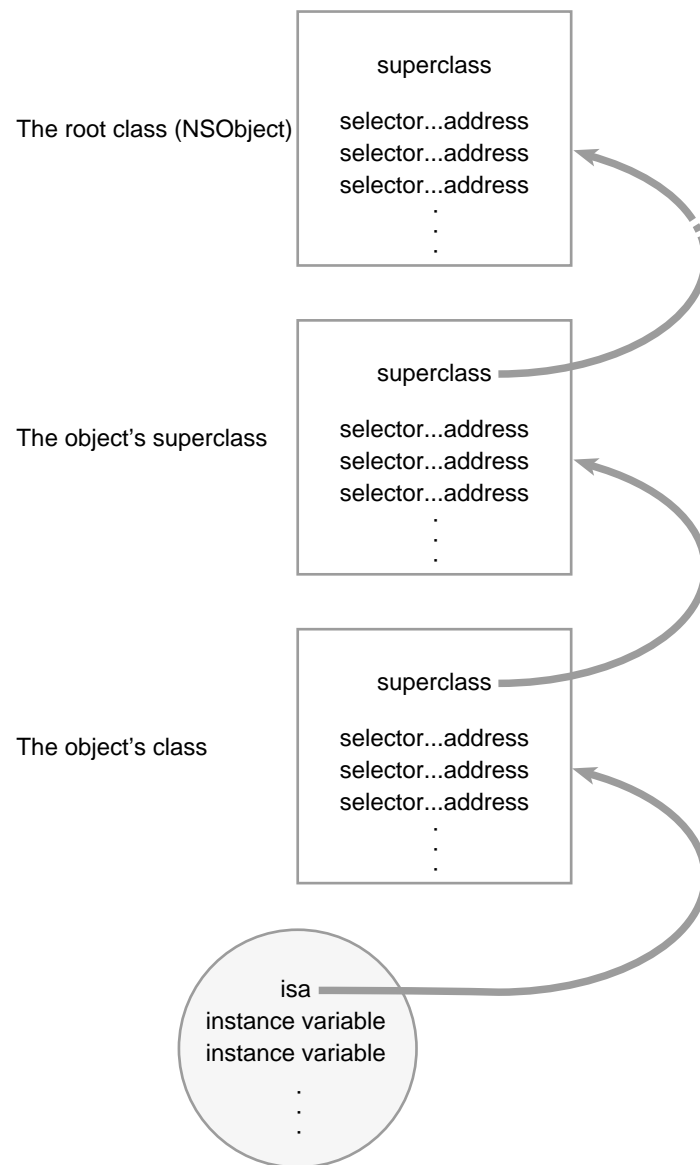

When a message is sent to an object, the messaging function follows the object's `isa` pointer to the class structure where it looks up the method selector in the dispatch table. If it can't find the selector there, `objc_msgSend()` follows the pointer to the superclass and tries to find the selector in its dispatch table. Successive failures cause `objc_msgSend()` to climb the class hierarchy until it reaches the `NSObject` class. Once it locates the selector, it calls the method entered in the table and passes it the receiving object's data structure.

---

This is the way that method implementations are chosen at run time—or, in the jargon of object-oriented programming, that methods are dynamically bound to messages.

To speed the messaging process, the run-time system caches the selectors and addresses of methods as they are used. There's a separate cache for each class, and it can contain selectors for inherited methods as well as for methods defined in the class. Before searching the dispatch tables, the messaging routine first checks the cache of the receiving object's class (on the theory that a method that was used once may likely be used again). If the method selector is in the cache, messaging is only slightly slower than a function call. Once a program has been running long enough to “warm up” its caches, almost all the messages it sends will find a cached method. Caches grow dynamically to accommodate new messages as the program runs.

### Selectors

For efficiency, full ASCII names are not used as method selectors in compiled code. Instead, the compiler writes each method name into a table, then pairs the name with a unique identifier that will represent the method at run time. The run-time system makes sure each identifier is unique: No two selectors are the same, and all methods with the same name have the same selector. Compiled selectors are assigned to a special type, SEL, to distinguish them from other data. Valid selectors are never 0.

A compiled selector contains fields of coded information that aid run-time messaging. You should therefore let the system assign SEL identifiers to methods; it won't work to assign them arbitrarily yourself.

The `@selector()` directive lets Objective-C source code refer to the compiled selector, rather than to the full method name. Here the selector for `setWidth:height:` is assigned to the `setWidthHeight` variable:

```
SEL setWidthHeight;
setWidthHeight = @selector(setWidth:height:);
```

It's most efficient to assign values to SEL variables at compile time with the `@selector()` directive. However, in some cases, a program may need to convert a character string to a selector at run time. This can be done with the `sel_getUid()` function:

```
setWidthHeight = sel_getUid(aBuffer);
```

Conversion in the opposite direction is also possible. The `sel_getName()` function returns a method name for a selector:

```
char *method;
method = sel_getName(setWidthHeight);
```

These and other run-time functions are described in the OPENSTEP framework reference documentation.

### Methods and Selectors

Compiled selectors identify method names, not method implementations. Rectangle's `display` method, for example, will have the same selector as `display` methods defined in other classes. This is essential for polymorphism and dynamic binding; it lets you send the same message to receivers belonging to different classes. If there were one selector per method implementation, a message would be no different than a function call.

A class method and an instance method with the same name are assigned the same selector. However, because of their different domains, there's no confusion between the two. A class could define a `display` class method in addition to a `display` instance method.

### Method Return and Argument Types

The messaging routine has access to method implementations only through selectors, so it treats all methods with the same selector alike. It discovers the return type of a method, and the data types of its arguments, from the selector. Therefore, except for messages sent to statically typed receivers, dynamic binding requires all implementations of identically named methods to have the same return type and the same argument types. (Statically typed receivers are an exception to this rule, since the compiler can learn about the method implementation from the class type.)

Although identically named class methods and instance methods are represented by the same selector, they can have different argument and return types.

### Varying the Message at Run Time

The `performSelector:`, `performSelector:withObject:`, and `performSelector:withObject:withObject:` methods, defined in the NSObject protocol, take SEL identifiers as their initial arguments. All three methods map directly into the messaging function. For example,

---

```
[friend performSelector:@selector(gossipAbout:)
    withObject:aNeighbor];
```

is equivalent to:

```
[friend gossipAbout:aNeighbor];
```

These methods make it possible to vary a message at run time, just as it's possible to vary the object that receives the message. Variable names can be used in both halves of a message expression:

```
id helper = getTheReceiver();
SEL request = getTheSelector();
[helper performSelector:request];
```

In this example, the receiver (*helper*) is chosen at run time (by the fictitious `getTheReceiver()` function), and the method the receiver is asked to perform (*request*) is also determined at run time (by the equally fictitious `getTheSelector()` function).

**Note:** `performSelector:` and its companion methods return an `id`. If the method that's performed returns a different type, it should be cast to the proper type. (However, casting won't work for all types; the method should return a pointer or a type compatible with a pointer.)

### The Target-Action Paradigm

In its treatment of user-interface controls, the OpenStep Application Kit makes good use of the ability to vary both the receiver and the message.

NSControls are graphical devices that can be used to give instructions to an application. Most resemble real-world control devices such as buttons, switches, knobs, text fields, dials, menu items, and the like. In software, these devices stand between the application and the user. They interpret events coming from hardware devices like the keyboard and mouse and translate them into application-specific instructions. For example, a button labeled "Find" would translate a mouse click into an instruction for the application to start searching for something.

The Application Kit defines a template for creating control devices and defines a few "off-the-shelf" devices of its own. For example, the `NSButtonCell` class

defines an object that you can assign to an `NSMatrix` and initialize with a size, a label, a picture, a font, and a keyboard alternative. When the user clicks the button (or uses the keyboard alternative), the `NSButtonCell` sends a message instructing the application to do something. To do this, an `NSButtonCell` must be initialized not just with an image, a size, and a label, but with directions on what message to send and who to send it to. Accordingly, an `NSButtonCell` can be initialized for an *action message*, the method selector it should use in the message it sends, and a *target*, the object that should receive the message.

```
[myButtonCell setAction:@selector(reapTheWind:)];  
[myButtonCell setTarget:anObject];
```

The `NSButtonCell` sends the message using `NSObject`'s `performSelector:withObject:` method. All action messages take a single argument, the `id` of the control device sending the message.

If Objective-C didn't allow the message to be varied, all `NSButtonCells` would have to send the same message; the name of the method would be frozen in the `NSButtonCell` source code. Instead of simply implementing a mechanism for translating user actions into action messages, `NSButtonCells` and other controls would have to constrain the content of the message. This would make it difficult for any object to respond to more than one `NSButtonCell`. There would either have to be one target for each button, or the target object would have to discover which button the message came from and act accordingly. Each time you rearranged the user interface, you'd also have to re-implement the method that responds to the action message. This would be an unnecessary complication that Objective-C happily avoids.

### Avoiding Messaging Errors

If an object receives a message to perform a method that isn't in its repertoire, an error results. It's the same sort of error as calling a nonexistent function. But because messaging occurs at run time, the error often won't be evident until the program executes.

It's relatively easy to avoid this error when the message selector is constant and the class of the receiving object is known. As you're programming, you can check to be sure that the receiver is able to respond. If the receiver is statically typed, the compiler will check for you.

However, if the message selector or the class of the receiver varies, it may be necessary to postpone this check until run time. The `respondToSelector:` method, defined in the `NSObject` class, determines whether a potential receiver can

---

respond to a potential message. It takes the method selector as an argument and returns whether the receiver has access to a method matching the selector:

```
if ( [anObject respondsToSelector:@selector(setOrigin:)] )
    [anObject setOrigin:0.0 :0.0];
else
    fprintf(stderr, "%s can't be placed\n",
           [anObject [NSStringFromClass([anObject class]) cString]])
```

The `respondsToSelector:` test is especially important when sending messages to objects that you don't have control over at compile time. For example, if you write code that sends a message to an object represented by a variable that others can set, you should check to be sure the receiver implements a method that can respond to the message.

**Note:** An object can also arrange to have the messages that it receives forwarded to other objects if it can't respond to them directly itself. In that case, it will appear that the object can't handle the message, even though it responds to it indirectly by assigning it to another object. Forwarding is discussed in Chapter 4, "The Run-Time System."

### Hidden Arguments

When the messaging function finds the procedure that implements a method, it calls the procedure and passes it all the arguments in the message. It also passes the procedure two hidden arguments:

- The receiving object
- The selector for the method

These arguments give every method implementation explicit information about the two halves of the message expression that invoked it. They're said to be "hidden" because they aren't declared in the source code that defines the method. They're inserted into the implementation when the code is compiled.

Although these arguments aren't explicitly declared, source code can still refer to them (just as it can refer to the receiving object's instance variables). A method refers to the receiving object as `self`, and to its own selector as `_cmd`. In the example below, `_cmd` refers to the selector for the `strange` method and `self` to the object that receives a `strange` message.

```

- strange
{
    id target = getTheReceiver();
    SEL action = getTheMethod();

    if ( target == self || action == _cmd )
        return nil;
    return [target performSelector:action];
}

```

`self` is the more useful of the two arguments. It is, in fact, the way the receiving object's instance variables are made available to the method definition.

Although it can make your API more confusing, some methods that have no other meaningful return value return `self`, rather than `void`. This enables such messages to be nested in source code. For example, if `setWidthHeight:`, `setFilled:`, and `setFillColor:` all returned `self`, you could write code like the following:

```

[[myRect setWidth:10.0 height:5.0] setFilled:YES]
    setFillColor:Green];

```

`self` is discussed in more detail in the next section.

### Messages to `self` and `super`

Objective-C provides two terms that can be used within a method definition to refer to the object that performs the method—`self` and `super`.

Suppose, for example, that you define a `reposition` method that needs to change the coordinates of whatever object it acts on. It can invoke the `setOrigin:` method to make the change. All it needs to do is send a `setOrigin:` message to the very same object that the `reposition` message itself was sent to. When you're writing the `reposition` code, you can refer to that object as either `self` or `super`. The `reposition` method could read either:

```

- reposition
{
    . . .
    [self setOrigin:someX :someY];
    . . .
}

```

or:

---

```
- reposition
{
    . . .
    [super setOrigin:someX :someY];
    . . .
}
```

Here `self` and `super` both refer to the object receiving a `reposition` message, whatever object that may happen to be. The two terms are quite different, however. `self` is one of the hidden arguments that the messaging routine passes to every method; it's a local variable that can be used freely within a method implementation, just as the names of instance variables can be. `super` is a term that substitutes for `self` only as the receiver in a message expression. As receivers, the two terms differ principally in how they affect the messaging process:

- `self` searches for the method implementation in the usual manner, starting in the dispatch table of the receiving object's class. In the example above, it would begin with the class of the object receiving the `reposition` message.
- `super` starts the search for the method implementation in a very different place. It begins in the superclass of the class that defines the method where `super` appears. In the example above, it would begin with the superclass of the class where `reposition` is defined.

Wherever `super` receives a message, the compiler substitutes another messaging routine for `objc_msgSend()`. The substitute routine looks directly to the superclass of the defining class—that is, to the superclass of the class sending the message to `super`—rather than to the class of the object receiving the message.

### An Example

The difference between `self` and `super` becomes clear in a hierarchy of three classes. Suppose, for example, that we create an object belonging to a class called `Low`. `Low`'s superclass is `Mid`; `Mid`'s superclass is `High`. All three classes define a method called `negotiate`, which they use for a variety of purposes. In addition, `Mid` defines an ambitious method called `makeLastingPeace`, which also has need of the `negotiate` method. This is illustrated in the following figure:

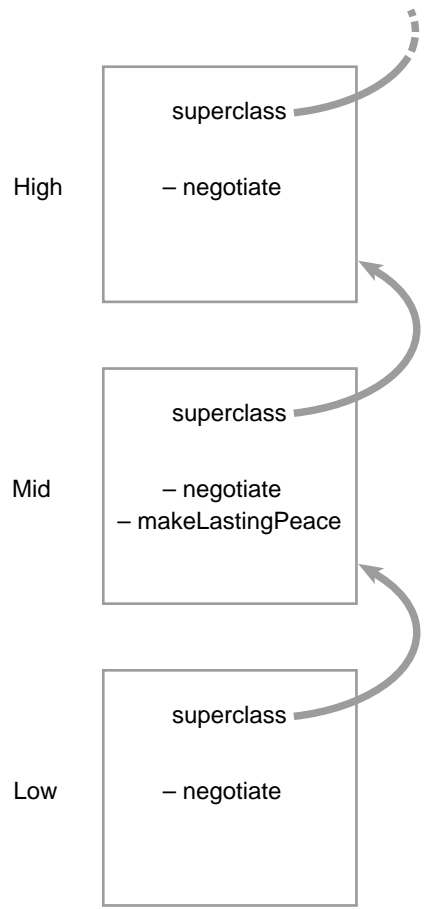

We now send a message to our Low object to perform the `makeLastingPeace` method, and `makeLastingPeace`, in turn, sends a `negotiate` message to the same Low object. If source code calls this object `self`,

```
- makeLastingPeace
{
    [self negotiate];
    . . .
}
```

the messaging routine will find the version of `negotiate` defined in Low, `self`'s class. However, if source code calls this object `super`,

---

```
- makeLastingPeace
{
    [super negotiate];
    . . .
}
```

the messaging routine will find the version of `negotiate` defined in `High`. It ignores the receiving object's class (`Low`) and skips to the superclass of `Mid`, since `Mid` is where `makeLastingPeace` is defined. Neither message finds `Mid`'s version of `negotiate`.

As this example illustrates, `super` provides a way to bypass a method that overrides another method. Here it enabled `makeLastingPeace` to avoid the `Mid` version of `negotiate` that redefined the original `High` version.

Not being able to reach `Mid`'s version of `negotiate` may seem like a flaw, but, under the circumstances, it's right to avoid it:

- The author of the `Low` class intentionally overrode `Mid`'s version of `negotiate` so that instances of the `Low` class (and its subclasses) would invoke the redefined version of the method instead. The designer of `Low` didn't want `Low` objects to perform the inherited method.
- In sending the message to `super`, the author of `Mid`'s `makeLastingPeace` method intentionally skipped over `Mid`'s version of `negotiate` (and over any versions that might be defined in classes like `Low` that inherit from `Mid`) to perform the version defined in the `High` class. `Mid`'s designer wanted to use the `High` version of `negotiate` and no other.

`Mid`'s version of `negotiate` could still be used, but it would take a direct message to a `Mid` instance to do it.

### Using `super`

Messages to `super` allow method implementations to be distributed over more than one class. You can override an existing method to modify or add to it, and still incorporate the original method in the modification:

```
- negotiate
{
    . . .
    return [super negotiate];
}
```

For some tasks, each class in the inheritance hierarchy can implement a method that does part of the job and pass the message on to `super` for the rest. The `init` method, which initializes a newly allocated instance, is designed to work like this. Each `init` method has responsibility for initializing the instance variables defined in its class. But before doing so, it sends an `init` message to `super` to have the classes it inherits from initialize their instance variables. Each version of `init` follows this same procedure, so classes initialize their instance variables in the order of inheritance:

```
- (id)init
{
    [super init];
    . . .
}
```

It's also possible to concentrate core functionality in one method defined in a superclass, and have subclasses incorporate the method through messages to `super`. For example, every class method that creates a new instance must allocate storage for the new object and initialize its `isa` pointer to the class structure. This is typically left to the `alloc` and `allocWithZone:` methods defined in the `NSObject` class. If another class overrides these methods for any reason (a rare case), it can still get the basic functionality by sending a message to `super`.

### Redefining `self`

`super` is simply a flag to the compiler telling it where to begin searching for the method to perform; it's used only as the receiver of a message. But `self` is a variable name that can be used in any number of ways, even assigned a new value.

There's a tendency to do just that in definitions of class methods. Class methods are often concerned, not with the class object, but with instances of the class. For example, a method might combine allocation and initialization of an instance:

```
+ (id)newRect
{
    return [[self alloc] init];
}
```

In such a method, it's tempting to send messages to the instance and to call the instance `self`, just as in an instance method. But that would be an error. `self` and `super` both refer to the receiving object—the object that gets a message telling it

---

to perform the method. Inside an instance method, `self` refers to the instance; but inside a class method, `self` refers to the class object.

Before a class method can send a message telling `self` to perform an instance method, it must redefine `self` to be the instance:

```
+ (id)newRectofColor:(NSColor *)aColor
{
    self = [[self alloc] init];
    [self setPrimaryColor:aColor];
    return self;
}
```

The method shown above is a class method, so, initially, `self` refers to the class object. It's as the class object that `self` receives the `alloc` message. `self` is then redefined to be the instance that `alloc` returns and `init` initializes. It's as the new instance that it receives the `setPrimaryColor:` message.

To avoid confusion, it's usually better to use a variable other than `self` to refer to an instance inside a class method:

```
+ (id)newRectofColor:(NSColor *)aColor
{
    id newInstance = [[self alloc] init];
    [newInstance setPrimaryColor:aColor];
    return newInstance;
}
```

**Note:** In these examples, the class method sends messages (`init` and `setPrimaryColor:`) to initialize the instance. It doesn't assign a new value directly to an instance variable as an instance method might have done:

```
linePattern = aPattern;
primaryColor = aColor;
```

Only instance variables of the receiver can be directly set this way. Because the receiver for a class method (the class object) has no instance variables, this syntax can't be used. However, if `newInstance` had been statically typed, something similar would have been possible:

```
newInstance->linePattern = aPattern;
```

See “Referring to Instance Variables” earlier in this chapter for more on when this syntax is permitted.

*Chapter 3*

Objective-C Extensions



---

The preceding chapter has all you need to know about Objective-C to define classes and design programs in the language. It covers basic Objective-C syntax and explains the messaging process in detail.

Class definitions are at the heart of object-oriented programming, but they're not the only mechanism for structuring object definitions in Objective-C. This chapter discusses two other ways of declaring methods and associating them with a class:

- Categories can compartmentalize a class definition or extend an existing one.
- Protocols declare methods that can be implemented by any class.

The chapter also explains how static typing works and takes up some lesser used features of Objective-C, including ways to temporarily overcome its inherent dynamism.

## Categories

You can add methods to a class by declaring them in an interface file under a category name and defining them in an implementation file under the same name. The category name indicates that the methods are additions to a class declared elsewhere, not a new class.

A category can be an alternative to a subclass. Rather than define a subclass to extend an existing class, through a category you can add methods to the class directly. For example, you could add categories to NSArray and other OpenStep classes. As in the case of a subclass, you don't need source code for the class you're extending.

The methods the category adds become part of the class type. For example, methods added to the NSArray class in a category will be among the methods the compiler will expect an NSArray instance to have in its repertoire. Methods added to the NSArray class in a subclass would not be included in the NSArray type. (This matters only for statically typed objects, since static typing is the only way the compiler can know an object's class.)

Category methods can do anything that methods defined in the class proper can do. At run time, there's no difference. The methods the category adds to the class are inherited by all the class's subclasses, just like other methods.

### Adding to a Class

The declaration of a category interface looks very much like a class interface declaration—except the category name is listed within parentheses after the class name and the superclass isn't mentioned. Unless its methods don't access any instance variables of the class, the category must import the interface file for the class it extends:

```
#import "ClassName.h"

@interface ClassName ( CategoryName )
method declarations
@end
```

The implementation, as usual, imports its own interface. Assuming that interface and implementation files are named after the category, a category implementation looks like this:

```
#import "CategoryName.h"

@implementation ClassName ( CategoryName )
method definitions
@end
```

Note that a category can't declare any new instance variables for the class; it includes only methods. However, all instance variables within the scope of the class are also within the scope of the category. That includes all instance variables declared by the class, even ones declared `@private`.

There's no limit to the number of categories that you can add to a class, but each category name must be different, and each should declare and define a different set of methods.

The methods added in a category can be used to extend the functionality of the class or override methods the class inherits. A category can also override methods declared in the class interface. However, it cannot reliably override methods declared in another category of the same class. A category is not a substitute for a subclass. It's best if categories don't attempt to redefine methods that aren't explicitly declared in the class's `@interface` section. Also note that a class shouldn't define the same method more than once.

**Note:** When a category overrides an inherited method, the new version can, as usual, incorporate the inherited version through a message to `super`. But there's

---

no way for a category method to incorporate a method with the same name defined for the same class.

#### How Categories Are Used

Categories can be used to extend classes defined by other implementors—for example, you can add methods to the classes defined in the OpenStep frameworks. The added methods will be inherited by subclasses and will be indistinguishable at run time from the original methods of the class.

Categories can also be used to distribute the implementation of a new class into separate source files—for example, you could group the methods of a large class into several categories and put each category in a different file. When used like this, categories can benefit the development process in a number of ways:

- They provide a simple way of grouping related methods. Similar methods defined in different classes can be kept together in the same source file.
- They simplify the management of a large class when more than one developer is contributing to the class definition.
- They let you achieve some of the benefits of incremental compilation for a very large class.
- They can help improve locality of reference for commonly used methods.
- They enable you to configure a class differently for different applications, without having to maintain different versions of the same source code.

Categories are also used to declare informal protocols, as discussed under “Protocols” below.

#### Categories of the Root Class

A category can add methods to any class, including the root class. Methods added to NSObject become available to all classes that are linked to your code. While this can be useful at times, it can also be quite dangerous. Although it may seem that the modifications the category makes are well understood and of limited impact, inheritance gives them a wide scope. You may be making unintended changes to unseen classes; you may not know all the consequences of what you’re doing. Moreover, others who are unaware of your changes won’t understand what they’re doing.

In addition, there are two other considerations to keep in mind when implementing methods for the root class:

- Messages to `super` are invalid (there is no superclass).
- Class objects can perform instance methods defined in the root class.

Normally, class objects can perform only class methods. But instance methods defined in the root class are a special case. They define an interface to the runtime system that all objects inherit. Class objects are full-fledged objects and need to share the same interface.

This feature means that you need to take into account the possibility that an instance method you define in a category of the `NSObject` class might be performed not only by instances but by class objects as well. For example, within the body of the method, `self` might mean a class object as well as an instance. See the `NSObject` class specification in the *Foundation Framework Reference* for more information on class access to root instance methods.

## Protocols

Class and category interfaces declare methods that are associated with a particular class—mainly methods that the class implements. Informal and formal *protocols*, on the other hand, declare methods not associated with a class, but which any class, and perhaps many classes, might implement.

A protocol is simply a list of method declarations, unattached to a class definition. For example, these methods that report user actions on the mouse could be gathered into a protocol:

```
- (void)mouseDown:(NSEvent *)theEvent;  
- (void)mouseDragged:(NSEvent *)theEvent;  
- (void)mouseUp:(NSEvent *)theEvent;
```

Any class that wanted to respond to mouse events could adopt the protocol and implement its methods.

Protocols free method declarations from dependency on the class hierarchy, so they can be used in ways that classes and categories cannot. Protocols list methods that are (or may be) implemented somewhere, but the identity of the class that implements them is not of interest. What is of interest is whether or not a particular class *conforms* to the protocol—whether it has implementations of the methods the protocol declares. Thus objects can be grouped into types not just on the basis of similarities due to the fact that they inherit from the same class, but also on the basis of their similarity in conforming to the same protocol.

---

Classes in unrelated branches of the inheritance hierarchy might be typed alike because they conform to the same protocol.

Protocols can play a significant role in object-oriented design, especially where a project is divided among many implementors or it incorporates objects developed in other projects. OPENSTEP software uses them heavily to support interprocess communication through Objective-C messages.

However, an Objective-C program doesn't need to use protocols. Unlike class definitions and message expressions, they're optional. Some OPENSTEP frameworks use them; some don't. It all depends on the task at hand.

#### How Protocols Are Used

Protocols are useful in at least three different situations:

- To declare methods that others are expected to implement
- To declare the interface to an object while concealing its class
- To capture similarities among classes that are not hierarchically related

The following sections discuss these situations and the roles protocols can play.

#### **Methods for Others to Implement**

If you know the class of an object, you can look at its interface declaration (and the interface declarations of the classes it inherits from) to find what messages it responds to. These declarations advertise the messages it can receive. Protocols provide a way for it to also advertise the messages it sends.

Communication works both ways; objects send messages as well as receive them. For example, an object might delegate responsibility for a certain operation to another object, or it may on occasion simply need to ask another object for information. In some cases, an object might be willing to notify other objects of its actions so that they can take whatever collateral measures might be required.

If you develop the class of the sender and the class of the receiver as part of the same project (or if someone else has supplied you with the receiver and its interface file), this communication is easily coordinated. The sender simply imports the interface file of the receiver. The imported file declares the method selectors the sender uses in the messages it sends.

However, if you develop an object that sends messages to objects that aren't yet defined—objects that you're leaving for others to implement—you won't have the receiver's interface file. You need another way to declare the methods you use in messages but don't implement. A protocol serves this purpose. It informs

the compiler about methods the class uses and also informs other implementors of the methods they need to define to have their objects work with yours.

Suppose, for example, that you develop an object that asks for the assistance of another object by sending it `helpOut:` and other messages. You provide an assistant instance variable to record the outlet for these messages and define a companion method to set the instance variable. This method lets other objects register themselves as potential recipients of your object's messages:

```
- setAssistant:anObject
{
    assistant = anObject;
    return self;
}
```

Then, whenever a message is to be sent to the assistant, a check is made to be sure that the receiver implements a method that can respond:

```
- (BOOL)doWork
{
    . . .
    if ( [assistant respondsToSelector:@selector(helpOut:)] ) {
        [assistant helpOut:self];
        return YES;
    }
    return NO;
}
```

Since, at the time you write this code, you can't know what kind of object might register itself as the assistant, you can only declare a protocol for the `helpOut:` method; you can't import the interface file of the class that implements it.

### Anonymous Objects

A protocol can also be used to declare the methods of an *anonymous* object, an object of unknown class. An anonymous object may represent a service or handle a limited set of functions, especially where only one object of its kind is needed. (Objects that play a fundamental role in defining an application's architecture and objects that you must initialize before using are not good candidates for anonymity.)

Objects can't be anonymous to their developers, of course, but they can be anonymous when the developer supplies them to someone else. For example, an anonymous object might be part of a framework or be located in a remote process:

- 
- Someone who supplies a framework or a suite of objects for others to use can include objects that are not identified by a class name or an interface file. Lacking the name and class interface, users have no way of creating instances of the class. Instead, the supplier must provide a ready-made instance. Typically, a method in another class returns a usable object:

```
id formatter = [receiver formattingService];
```

The object returned by the method is an object without a class identity, at least not one the supplier is willing to reveal. For it to be of any use at all, the supplier must be willing to identify at least some of the messages that it can respond to. This is done by associating the object with a list of methods declared in a protocol.

- It's possible to send Objective-C messages to *remote objects*—objects in other applications. (The next section, “Remote Messaging,” discusses this possibility in more detail.)

Each application has its own structure, classes, and internal logic. But you don't need to know how another application works or what its components are to communicate with it. As an outsider, all you need to know is what messages you can send (the protocol) and where to send them (the receiver).

An application that publishes one of its objects as a potential receiver of remote messages must also publish a protocol declaring the methods the object will use to respond to those messages. It doesn't have to disclose anything else about the object. The sending application doesn't need to know the class of the object or use the class in its own design. All it needs is the protocol.

Protocols make anonymous objects possible. Without a protocol, there would be no way to declare an interface to an object without identifying its class.

**Note:** Even though the supplier of an anonymous object won't reveal its class, the object itself will reveal it at run time. A class message will return the anonymous object's class. However, there's usually little point in discovering this extra information; the information in the protocol is sufficient.

### Non-Hierarchical Similarities

If more than one class implements a set of methods, those classes are often grouped under an abstract class that declares the methods they have in common. Each subclass may reimplement the methods in its own way, but the inheritance

hierarchy and the common declaration in the abstract class captures the essential similarity between the subclasses.

However, sometimes it's not possible to group common methods in an abstract class. Classes that are unrelated in most respects might nevertheless need to implement some similar methods. This limited similarity may not justify a hierarchical relationship. For example, many different kinds of classes might implement methods to facilitate reference counting (this is just an example, since the Foundation Framework already implements reference counting for you):

```
- setRefCount:(int)count;  
- (int)RefCount;  
- incrementCount;  
- decrementCount;
```

These methods could be grouped into a protocol and the similarity between implementing classes accounted for by noting that they all conform to the same protocol.

Objects can be typed by this similarity (the protocols they conform to), rather than by their class. For example, an NSMatrix must communicate with the objects that represent its cells. The NSMatrix could require each of these objects to be a kind of NSCell (a type based on class) and rely on the fact that all objects that inherit from the NSCell class will have the methods needed to respond to NSMatrix messages. Alternatively, the NSMatrix could require objects representing cells to have methods that can respond to a particular set of messages (a type based on protocol). In this case, the NSMatrix wouldn't care what class a cell object belonged to, just that it implemented the methods.

### Informal Protocols

The simplest way of declaring a protocol is to group the methods in a category declaration:

```
@interface NSObject ( RefCounting )  
- setRefCount:(int)count;  
- (int)RefCount;  
- incrementCount;  
- decrementCount;  
@end
```

Informal protocols are typically declared as categories of the NSObject class, since that broadly associates the method names with any class that inherits from

---

NSObject. Because all classes inherit from the root class, the methods aren't restricted to any part of the inheritance hierarchy. (It would also be possible to declare an informal protocol as a category of another class to limit it to a certain branch of the inheritance hierarchy, but there is little reason to do so.)

When used to declare a protocol, a category interface doesn't have a corresponding implementation. Instead, classes that implement the protocol declare the methods again in their own interface files and define them along with other methods in their implementation files.

An informal protocol bends the rules of category declarations to list a group of methods but not associate them with any particular class or implementation.

Being informal, protocols declared in categories don't receive much language support. There's no type checking at compile time nor a check at run time to see whether an object conforms to the protocol. To get these benefits, you must use a formal protocol.

#### Formal Protocols

The Objective-C language provides a way to formally declare a list of methods as a protocol. Formal protocols are supported by the language and the run-time system. For example, the compiler can check for types based on protocols, and objects can introspect at run time to report whether or not they conform to a protocol.

Formal protocols are declared with the `@protocol` directive:

```
@protocol ProtocolName
method declarations
@end
```

For example, the reference-counting protocol could be declared like this:

```
@protocol ReferenceCounting
- setRefCount:(int)count;
- (int)RefCount;
- incrementCount;
- decrementCount;
@end
```

Unlike class names, protocol names don't have global visibility. They live in their own name space.

A class is said to *adopt* a formal protocol if it agrees to implement the methods the protocol declares. Class declarations list the names of adopted protocols within angle brackets after the superclass name:

```
@interface ClassName : ItsSuperclass < protocol list >
```

Categories adopt protocols in much the same way:

```
@interface ClassName ( CategoryName ) < protocol list >
```

Names in the protocol list are separated by commas.

A class or category that adopts a protocol must import the header file where the protocol is declared. The methods declared in the adopted protocol are not declared elsewhere in the class or category interface.

It's possible for a class to simply adopt protocols and declare no other methods. For example, this class declaration,

```
@interface Formatter : NSObject < Formatting, Prettifying >
@end
```

adopts the `Formatting` and `Prettifying` protocols, but declares no instance variables or methods of its own.

A class or category that adopts a protocol is obligated to implement all the methods the protocol declares. The compiler will issue a warning if it does not. The `Formatter` class above would define all the methods declared in the two protocols it adopts, in addition to any it might have declared itself.

Adopting a protocol is similar in some ways to declaring a superclass. Both assign methods to the new class. The superclass declaration assigns it inherited methods; the protocol assigns it methods declared in the protocol list.

### Protocol Objects

Just as classes are represented at run time by class objects and methods by selector codes, formal protocols are represented by a special data type—instances of the `Protocol` class. Source code that deals with a protocol (other than to use it in a type specification) must refer to the `Protocol` object.

---

In many ways, protocols are similar to class definitions. They both declare methods, and at run time they're both represented by objects—classes by class objects and protocols by Protocol objects. Like class objects, Protocol objects are created automatically from the definitions and declarations found in source code and are used by the run-time system. They're not allocated and initialized in program source code.

Source code can refer to a Protocol object using the `@protocol()` directive—the same directive that declares a protocol, except that here it has a set of trailing parentheses. The parentheses enclose the protocol name:

```
Protocol *counter = @protocol(ReferenceCounting);
```

This is the only way that source code can conjure up a Protocol object. Unlike a class name, a protocol name doesn't designate the object—except inside `@protocol()`.

The compiler creates a Protocol object for each protocol declaration it encounters, but only if the protocol is also:

- Adopted by a class, or
- Referred to somewhere in source code (using `@protocol()`).

Protocols that are declared but not used (except for type checking as described below) aren't represented by Protocol objects at run-time.

### Conforming to a Protocol

A class is said to *conform* to a formal protocol if it adopts the protocol or inherits from a class that adopts it. An instance of a class is said to conform to the same set of protocols its class conforms to.

Since a class must implement all the methods declared in the protocols it adopts, and those methods are inherited by its subclasses, saying that a class or an instance conforms to a protocol is tantamount to saying that it has in its repertoire all the methods that the protocol declares.

It's possible to check whether an object conforms to a protocol by sending it a `conformsTo:` message.

```
if ( [receiver conformsTo:@protocol(ReferenceCounting)] )  
    [receiver incrementCount];
```

The `conformsTo:` test is very much like the `respondsTo:` test for a single method, except that it tests whether a protocol has been adopted (and presumably all the methods it declares implemented) rather than just whether one particular method has been implemented. Because it checks for a whole list of methods, `conformsTo:` can be more efficient than `respondsTo:`.

The `conformsTo:` test is also very much like the `isKindOfClass:` test, except that it tests for a type based on a protocol rather than a type based on the inheritance hierarchy.

### Type Checking

Type declarations for objects can be extended to include formal protocols. Protocols thus offer the possibility of another level of type checking by the compiler, one that's more abstract since it's not tied to particular implementations.

In a type declaration, protocol names are listed between angle brackets after the type name:

```
- (id <Formatting>)formattingService;  
id <ReferenceCounting, AutoFreeing> anObject;
```

Just as static typing permits the compiler to test for a type based on the class hierarchy, this syntax permits the compiler to test for a type based on conformance to a protocol.

For example, if `Formatter` is an abstract class, this declaration

```
Formatter *anObject;
```

groups all objects that inherit from `Formatter` into a type and permits the compiler to check assignments against that type.

Similarly, this declaration,

```
id <Formatting> anObject;
```

groups all objects that conform to the `Formatting` protocol into a type, regardless of their positions in the class hierarchy. The compiler can check to be sure that only objects that conform to the protocol are assigned to the type.

---

In each case, the type groups similar objects—either because they share a common inheritance, or because they converge on a common set of methods.

The two types can be combined in a single declaration:

```
Formatter <Formatting> *anObject;
```

Protocols can't be used to type class objects. Only instances can be statically typed to a protocol, just as only instances can be statically typed to a class. (However, at run time, both classes and instances will respond to a `conformsTo:` message.)

### Protocols within Protocols

One protocol can incorporate others using the same syntax that classes use to adopt a protocol:

```
@protocol ProtocolName < protocol list >
```

All the protocols listed between angle brackets are considered part of the *ProtocolName* protocol. For example, if the Paging protocol incorporates the Formatting protocol,

```
@protocol Paging < Formatting >
```

any object that conforms to the Paging protocol will also conform to Formatting.  
Type declarations

```
id <Paging> someObject;
```

and `conformsTo:` messages

```
if ( [anotherObject conformsTo:@protocol(Paging)] )  
    . . .
```

need mention only the Paging protocol to test for conformance to Formatting as well.

When a class adopts a protocol, it must implement the methods the protocol declares, as mentioned earlier. In addition, it must conform to any protocols the adopted protocol incorporates. If an incorporated protocol incorporates still other protocols, the class must also conform to them. A class can conform to an incorporated protocol by either:

- Implementing the methods the protocol declares, or
- Inheriting from a class that adopts the protocol and implements the methods.

Suppose, for example, that the `Pager` class adopts the `Paging` protocol. If `Pager` is a subclass of `NSObject`,

```
@interface Pager : NSObject < Paging >
```

it must implement all the `Paging` methods, including those declared in the incorporated `Formatting` protocol. It adopts the `Formatting` protocol along with `Paging`.

On the other hand, if `Pager` is a subclass of `Formatter` (a class that independently adopts the `Formatting` protocol),

```
@interface Pager : Formatter < Paging >
```

it must implement all the methods declared in the `Paging` protocol proper, but not those declared in `Formatting`. `Pager` inherits conformance to the `Formatting` protocol from `Formatter`.

Note that a class can conform to a protocol without formally adopting it simply by implementing the methods declared in the protocol.

### Referring to Other Protocols

When working on complex applications, you occasionally find yourself writing code that looks like this:

```
#import "B.h"

@protocol A
- foo:(id <B>)anObject;
@end
```

---

where protocol B is declared like this:

```
#import "A.h"

@protocol B
- bar:(id <A>)anObject;
@end
```

In such a situation, circularity results and neither file will compile correctly. To break this recursive cycle, you must use the `@protocol` directive to make a forward reference to the needed protocol instead of importing the interface file where the protocol is defined. The following code excerpt illustrates how you would do this:

```
@protocol B;

@protocol A
- foo:(id <B>)anObject;
@end
```

Note that using the `@protocol` directive in this manner simply informs the compiler that “B” is a protocol to be defined later. It doesn’t import the interface file where protocol B is defined.

## Remote Messaging

Like most other programming languages, Objective-C was initially designed for programs that are executed as a single process in a single address space.

Nevertheless, the object-oriented model, where communication takes place between relatively self-contained units through messages that are resolved at run-time, would seem well suited for interprocess communication as well. It’s not hard to imagine Objective-C messages between objects that reside in different address spaces (that is, in different tasks) or in different threads of execution of the same task.

For example, in a typical server-client interaction, the client task might send its requests to a designated object in the server, and the server might target specific client objects for the notifications and other information it sends.

Or imagine an interactive application that needs to do a good deal of computation to carry out a user command. It could simply put up an attention panel telling the user to wait while it was busy, or it could isolate the processing work in a subordinate task, leaving the main part of the application free to accept user input. Objects in the two tasks would communicate through Objective-C messages.

Similarly, several separate processes could cooperate on the editing of a single document. There could be a different editing tool for each type of data in the document. One task might be in charge of presenting a unified user interface on-screen and of sorting out which user instructions were the responsibility of which editing tool. Each cooperating task could be written in Objective-C, with Objective-C messages being the vehicle of communication between the user interface and the tools and between one tool and another.

#### Distributed Objects

Remote messaging in Objective-C requires a run-time system that can establish connections between objects in different address spaces, recognize when a message is intended for a remote address, and transfer data from one address space to another. It must also mediate between the separate schedules of the two tasks; it has to hold messages until their remote receivers are free to respond to them.

OpenStep includes a *distributed objects* architecture that is essentially this kind of extension to the run-time system. Using distributed objects, you can send Objective-C messages to objects in other tasks or have messages executed in other threads of the same task. (When remote messages are sent between two threads of the same task, the threads are treated exactly like threads in different tasks.) Note that OpenStep's distributed objects system is built on top of the run-time system; it doesn't alter the fundamental behavior of your OpenStep objects.

To send a remote message, an application must first establish a connection with the remote receiver. Establishing the connection gives the application a proxy for the remote object in its own address space. It then communicates with the remote object through the proxy. The proxy assumes the identity of the remote object; it has no identity of its own. The application is able to regard the proxy as if it were the remote object; for most purposes, it *is* the remote object.

Remote messaging is diagrammed below, where object A communicates with object B through a proxy, and messages for B wait in a queue until B is ready to respond to them:

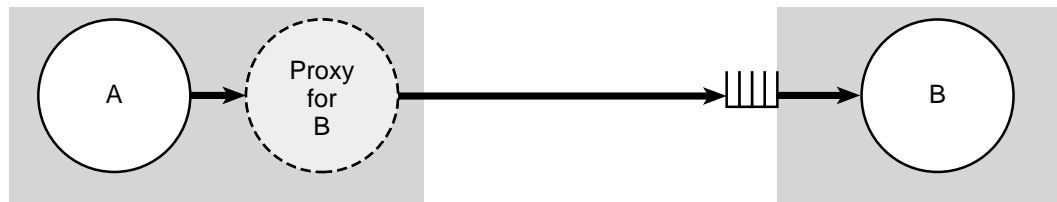

The sender and receiver are in different tasks and are scheduled independently of each other. So there's no guarantee that the receiver will be free to accept a message when the sender is ready to send it. Therefore, arriving messages are placed in a queue and retrieved at the convenience of the receiving application.

A proxy doesn't act on behalf of the remote object or need access to its class. It isn't a copy of the object, but a lightweight substitute for it. In a sense, it's transparent; it simply passes the messages it receives on to the remote receiver and manages the interprocess communication. Its main function is to provide a local address for an object that wouldn't otherwise have one. A proxy isn't fully transparent, however. For instance, a proxy doesn't allow you to directly set and get an object's instance variables.

A remote receiver is typically anonymous. Its class is hidden inside the remote application. The sending application doesn't need to know how that application is designed or what classes it uses. It doesn't need to use the same classes itself. All it needs to know is what messages the remote object responds to.

Because of this, an object that's designated to receive remote messages typically advertises its interface in a formal protocol. Both the sending and the receiving application declare the protocol—they both import the same protocol declaration. The receiving application declares it because the remote object must conform to the protocol. The sending application declares it to inform the compiler about the messages it sends and because it may use the `conformsTo:` method and the `@protocol()` directive to test the remote receiver. The sending application doesn't have to implement any of the methods in the protocol; it declares the protocol only because it initiates messages to the remote receiver.

The distributed objects architecture, including the `NSProxy` and `NSConnection` classes, is documented in the *Foundation Framework Reference*.

#### Language Support

Remote messaging raises not only a number of intriguing possibilities for program design, it also raises some interesting issues for the Objective-C language. Most of the issues are related to the efficiency of remote messaging

and the degree of separation that the two tasks should maintain while they're communicating with each other.

So that programmers can give explicit instructions about the intent of a remote message, Objective-C defines six type qualifiers that can be used when declaring methods inside a formal protocol:

```
oneway
in
out
inout
bycopy
byref
```

These modifiers are restricted to formal protocols; they can't be used inside class and category declarations. However, if a class or category adopts a protocol, its implementation of the protocol methods can use the same modifiers that are used to declare the methods.

The following sections explain how these modifiers are used.

### Synchronous and Asynchronous Messages

Consider first a method with just a simple return value:

```
- (BOOL) canDance;
```

When a `canDance` message is sent to a receiver in the same application, the method is invoked and the return value provided directly to the sender. But when the receiver is in a remote application, two underlying messages are required—one message to get the remote object to invoke the method, and the other message to send back the result of the remote calculation. This is illustrated in the figure below:

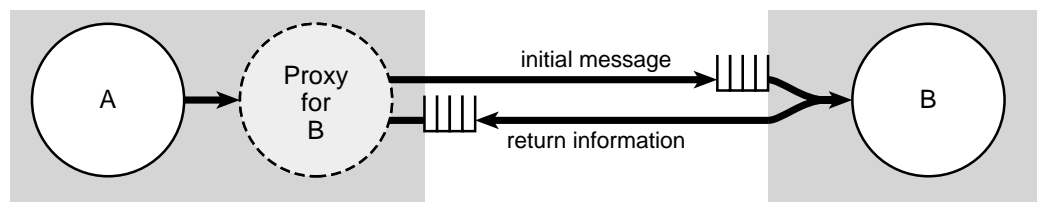

Most remote messages will be, at bottom, two-way (or “round trip”) remote procedure calls (RPCs) like this one. The sending application waits for the

---

receiving application to invoke the method, complete its processing, and send back an indication that it has finished, along with any return information requested. Waiting for the receiver to finish, even if no information is returned, has the advantage of coordinating the two communicating applications, of keeping them both “in sync.” For this reason, round-trip messages are often called *synchronous*. Synchronous messages are the default.

However, it’s not always necessary or a good idea to wait for a reply. Sometimes it’s sufficient simply to dispatch the remote message and return, allowing the receiver to get to the task when it will. In the meantime, the sender can go on to other things. Objective-C provides a return type modifier, *oneway*, to indicate that a method is used only for *asynchronous* messages:

```
- (oneway void)waltzAtWill;
```

Although *oneway* is a type qualifier (like *const*) and can be used in combination with a specific type name, such as *oneway float* or *oneway id*, the only such combination that makes any sense is *oneway void*. An asynchronous message can’t have a valid return value.

### Pointer Arguments

Next, consider methods that take pointer arguments. A pointer can be used to pass information to the receiver by reference. When invoked, the method looks at what’s stored in the address it’s passed.

```
- setTune:(struct tune *)aSong
{
    tune = *aSong;
    . . .
}
```

The same sort of argument can also be used to return information by reference. The method uses the pointer to find where it should place information requested in the message.

```
- getTune:(struct tune *)theSong
{
    . . .
    *theSong = tune;
}
```

The way the pointer is used makes a difference in how the remote message is carried out. In neither case can the pointer simply be passed to the remote object unchanged; it points to a memory location in the sender's address space and would not be meaningful in the address space of the remote receiver. The run-time system for remote messaging must make some adjustments behind the scenes.

If the argument is used to pass information by reference, the run-time system must dereference the pointer, ship the value it points to over to the remote application, store the value in an address local to that application, and pass that address to the remote receiver.

If, on the other hand, the pointer is used to return information by reference, the value it points to doesn't have to be sent to the other application. Instead, a value from the other application must be sent back and written into the location indicated by the pointer.

In the one case, information is passed on the first leg of the round trip. In the other case, information is returned on the second leg of the round trip. Because these cases result in very different actions on the part of the run-time system for remote messaging, Objective-C provides type modifiers that can clarify the programmer's intention:

- The type modifier `in` indicates that information is being passed in a message:

```
- setTune:(in struct tune *)aSong;
```

- The modifier `out` indicates that an argument is being used to return information by reference:

```
- getTune:(out struct tune *)theSong;
```

- A third modifier, `inout`, indicates that an argument is used both to provide information and to get information back:

```
- adjustTune:(inout struct tune *)aSong;
```

The OpenStep distributed objects system takes `inout` to be the default modifier for all pointer arguments except those declared `const`, for which `in` is the default. `inout` is the safest assumption but also the most time-consuming since it requires passing information in both directions. The only modifier that makes sense for

---

arguments passed by value (non-pointers) is `in`. While `in` can be used with any kind of argument, `out` and `inout` make sense only for pointers.

In C, pointers are sometimes used to represent composite values. For example, a string is represented as a character pointer (`char *`). Although in notation and implementation there's a level of indirection here, in concept there's not. Conceptually, a string is an entity in and of itself, not a pointer to something else.

In cases like this, the distributed objects system automatically dereferences the pointer and passes whatever it points to as if by value. Therefore, the `out` and `inout` modifiers make no sense with simple character pointers. It takes an additional level of indirection in a remote message to pass or return a string by reference:

```
- getTuneTitle:(out char **)theTitle;
```

The same is true of objects:

```
- adjustRectangle:(inout Rectangle **)theRect;
```

These conventions are enforced at run time, not by the compiler.

### Proxies and Copies

Finally, consider a method that takes an object as an argument:

```
- danceWith:(id)aPartner;
```

A `danceWith:` message passes an object `id` to the receiver. If the sender and receiver are in the same application, they would both be able to refer to the same *aPartner* object.

This is true even if the receiver is in a remote application, except that the receiver will need to refer to the object through a proxy (since the object isn't in its address space). The pointer that `danceWith:` delivers to a remote receiver is actually a pointer to the proxy. Messages sent to the proxy would be passed across the connection to the real object and any return information would be passed back to the remote application.

There are times when proxies may be unnecessarily inefficient, when it's better to send a copy of the object to the remote process so that it can interact with it directly in its own address space. To give programmers a way to indicate that this is intended, Objective-C provides a `bycopy` type modifier:

```
- danceWith:(bycopy id)aClone;
```

`bycopy` can also be used for return values:

```
- (bycopy)dancer;
```

It can similarly be used with `out` to indicate that an object returned by reference should be copied rather than delivered in the form of a proxy:

```
- getDancer:(bycopy out id *)theDancer;
```

**Note:** When a copy of an object is passed to another application, it cannot be anonymous. The application that receives the object must have the class of the object loaded in its address space.

`bycopy` makes so much sense for certain classes—classes that are intended to contain a collection of other objects, for instance—that often these classes are written so that a copy is sent to a remote receiver, instead of the usual reference. You can override this behavior with `byref`, however, thereby specifying that objects passed into or out of a method should all be passed by reference. Since passing by reference is the default behavior for the vast majority of Objective-C objects, you will rarely, if ever, make use of the `byref` keyword.

The only type that it makes sense for `bycopy` or `byref` to modify is an object, whether dynamically typed `id` or statically typed by a class name.

Although `bycopy` and `byref` can't be used inside class and category declarations, they can be used within formal protocols. For instance, you could write a formal protocol `foo` as follows:

```
@Protocol foo
- (bycopy)array;
@end
```

---

A class or category can then adopt your protocol `foo`. This allows you to construct protocols so that they provide “hints” as to how objects should be passed and returned by the methods described by the protocol.

## Static Options

Objective-C objects are dynamic entities. As many decisions about them as possible are pushed from compile time to run time:

- The memory for objects is *dynamically allocated* at run time by class methods that create new instances.
- Objects are *dynamically typed*. In source code (at compile time), any object can be of type `id` no matter what its class. The exact class of an `id` variable (and therefore its particular methods and data structure) isn’t determined until the program is running.
- Messages and methods are *dynamically bound*, as described under “How Messaging Works” in the previous chapter. A run-time procedure matches the method selector in the message to a method implementation that “belongs to” the receiver.

These features give object-oriented programs a great deal of flexibility and power, but there’s a price to pay. Messages are somewhat slower than function calls, for example, (though not much slower due to the efficiency of the run-time system) and the compiler can’t check the exact types (classes) of `id` variables.

To permit better compile-time type checking, and to make code more self-documenting, Objective-C allows objects to be statically typed with a class name rather than generically typed as `id`. It also lets you turn some of its object-oriented features off in order to shift operations from run time back to compile time.

### Static Typing

If a pointer to a class name is used in place of `id` in an object declaration,

```
Rectangle *thisObject;
```

the compiler restricts the declared variable to be either an instance of the class named in the declaration or an instance of a class that inherits from the named class. In the example above, `thisObject` can only be a `Rectangle` of some kind.

Statically typed objects have the same internal data structures as objects declared to be `ids`. The type doesn't affect the object; it affects only the amount of information given to the compiler about the object and the amount of information available to those reading the source code.

Static typing also doesn't affect how the object is treated at run time. Statically typed objects are dynamically allocated by the same class methods that create instances of type `id`. If `Square` is a subclass of `Rectangle`, the following code would still produce an object with all the instance variables of a `Square`, not just those of a `Rectangle`:

```
Rectangle *thisObject = [[Square alloc] init];
```

Messages sent to statically typed objects are dynamically bound, just as objects typed `id` are. The exact type of a statically typed receiver is still determined at run time as part of the messaging process. A `display` message sent to `thisObject`

```
[thisObject display];
```

will perform the version of the method defined in the `Square` class, not its `Rectangle` superclass.

By giving the compiler more information about an object, static typing opens up possibilities that are absent for objects typed `id`:

- In certain situations, it allows for compile-time type checking.
- It can free objects from the restriction that identically named methods must have identical return and argument types.
- It permits you to use the structure pointer operator to directly access an object's instance variables.

The first two topics are discussed in the sections below. The third was covered in the previous chapter under "Defining A Class."

---

## Type Checking

With the additional information provided by static typing, the compiler can deliver better type-checking services in two situations:

- When a message is sent to a statically typed receiver, the compiler can check to be sure that the receiver can respond. A warning is issued if the receiver doesn't have access to the method named in the message.
- When a statically typed object is assigned to a statically typed variable, the compiler can check to be sure that the types are compatible. A warning is issued if they're not.

An assignment can be made without warning provided the class of the object being assigned is identical to, or inherits from, the class of the variable receiving the assignment. This is illustrated in the example below.

```
Shape    *aShape;
Rectangle *aRect;

aRect = [[Rectangle alloc] init];
aShape = aRect;
```

Here `aRect` can be assigned to `aShape` because a `Rectangle` is a kind of `Shape`—the `Rectangle` class inherits from `Shape`. However, if the roles of the two variables are reversed and `aShape` is assigned to `aRect`, the compiler will generate a warning; not every `Shape` is a `Rectangle`. (For reference, see the figure in the previous chapter that shows the class hierarchy including `Shape` and `Rectangle`.)

There's no check when the expression on either side of the assignment operator is an `id`. A statically typed object can be freely assigned to an `id`, or an `id` to a statically typed object. Because methods like `alloc` and `init` return `ids`, the compiler doesn't check to be sure that a compatible object is returned to a statically typed variable. The following code is error-prone, but is allowed nonetheless:

```
Rectangle *aRect;
aRect = [[Shape alloc] init];
```

**Note:** This is consistent with the semantics of `void *` (pointer to `void`) in ANSI C. Just as `void *` is a generic pointer that eliminates the need for coercion in assignments between pointers, `id` is a generic pointer to objects that eliminates the need for coercion to a particular class in assignments between objects.

### Return and Argument Types

In general, methods that share the same selector (the same name) must also share the same return and argument types. This constraint is imposed by dynamic binding. Because the class of a message receiver, and therefore class-specific details about the method it's asked to perform, can't be known at compile time, the compiler must treat all methods with the same name alike. When it prepares information on method return and argument types for the run-time system, it creates just one method description for each method selector.

However, when a message is sent to a statically typed object, the class of the receiver is known by the compiler. The compiler has access to class-specific information about the methods. Therefore, the message is freed from the restrictions on its return and argument types.

### Static Typing to an Inherited Class

An instance can be statically typed to its own class or to any class that it inherits from. All instances, for example, can be statically typed as `NSObject`s.

However, the compiler understands the class of a statically typed object only from the class name in the type designation, and it does its type checking accordingly. Typing an instance to an inherited class can therefore result in discrepancies between what the compiler thinks would happen at run time and what will actually happen.

For example, if you statically type a `Rectangle` instance as a `Shape`,

```
Shape *myRect = [[Rectangle alloc] init];
```

the compiler will treat it as a `Shape`. If you send the object a message to perform a `Rectangle` method,

```
BOOL solid = [myRect isFilled];
```

the compiler will complain. The `isFilled` method is defined in the `Rectangle` class, not in `Shape`.

However, if you send it a message to perform a method that the `Shape` class knows about,

---

```
[myRect display];
```

the compiler won't complain, even though Rectangle overrides the method. At run time, Rectangle's version of the method will be performed.

Similarly, suppose that the Upper class declares a worry method that returns a double,

```
- (double)worry;
```

and the Middle subclass of Upper overrides the method and declares a new return type:

```
- (int)worry;
```

If an instance is statically typed to the Upper class, the compiler will think that its worry method returns a double, and if an instance is typed to the Middle class, it will think that worry returns an int. Errors will obviously result if a Middle instance is typed to the Upper class. The compiler will inform the run-time system that a worry message sent to the object will return a double, but at run time it will actually return an int and generate an error.

Static typing can free identically named methods from the restriction that they must have identical return and argument types, but it can do so reliably only if the methods are declared in different branches of the class hierarchy.

### Getting a Method Address

The only way to circumvent dynamic binding is to get the address of a method and call it directly as if it were a function. This might be appropriate on the rare occasions when a particular method will be performed many times in succession and you want to avoid the overhead of messaging each time the method is performed.

With a method defined in the NSObject class, `methodForSelector:`, you can ask for a pointer to the procedure that implements a method, then use the pointer to call the procedure. The pointer that `methodForSelector:` returns must be carefully cast to the proper function type. Both return and argument types should be included in the cast.

The example below shows how the procedure that implements the `setFilled:` method might be called:

```
void (*setter)(id, SEL, BOOL);
int i;

setter = (void (*)(id, SEL, BOOL))[target
    methodForSelector:@selector(setFilled:)];
for ( i = 0; i < 1000, i++ )
    setter(targetList[i], @selector(setFilled:), True);
```

The first two arguments passed to the procedure are the receiving object (`self`) and the method selector (`_cmd`). These arguments are hidden in method syntax but must be made explicit when the method is called as a function.

Using `methodForSelector:` to circumvent dynamic binding saves most of the time required by messaging. However, the savings will be significant only where a particular message will be repeated many times, as in the `for` loop shown above.

Note that `methodForSelector:` is provided by the run-time system; it's not a feature of the Objective-C language itself.

### Getting an Object Data Structure

A fundamental tenet of object-oriented programming is that the data structure of an object is private to the object. Information stored there can be accessed only through messages sent to the object. Although it is generally considered a poor programming practice, there *is* a way to strip an object data structure of its "objectness" and treat it like any other C structure. This makes all the object's instance variables publicly available.

When given a class name as an argument, the `@defs()` directive produces the declaration list for an instance of the class. This list is useful only in declaring structures, so `@defs()` can appear only in the body of a structure declaration. This code, for example, declares a structure that would be identical to the template for an instance of the `Worker` class:

```
struct workerDef {
    @defs(Worker)
} *public;
```

Here `public` is declared as a pointer to a structure that's essentially indistinguishable from a `Worker` instance. With a little help from a type cast, a

---

Worker id can be assigned to the pointer. The object's instance variables can then be accessed publicly through the pointer:

```
id aWorker;
aWorker = [[Worker alloc] init];

public = (struct workerDef *)aWorker;
public->boss = nil;
```

This technique of turning an object into a structure makes all of its instance variables public, no matter whether they were declared `@private`, `@protected`, or `@public`.

Objects generally aren't designed with the expectation that they'll be turned into C structures. You may want to use `@defs()` for classes you define entirely yourself, but it should not be applied to classes found in a framework or to classes you define that inherit from framework classes.

## Type Encoding

To assist the run-time system, the compiler encodes the return and argument types for each method in a character string and associates the string with the method selector. The coding scheme it uses might also be of use in other contexts and so is made publicly available with the `@encode()` directive. When given a type specification, `@encode()` returns a string encoding that type. The type can be a basic type such as an int, a pointer, a tagged structure or union, or a class name—anything, in fact, that can be used as an argument to the C `sizeof()` operator.

```
char *buf1 = @encode(int **);
char *buf2 = @encode(struct key);
char *buf3 = @encode(Rectangle);
```

The table below lists the type codes. Note that many of them overlap with the codes you use when encoding an object for purposes of archiving or distribution. However, there are codes listed here that you can't use when writing a coder, and there are codes that you may want to use when writing a coder that aren't generated by `@encode()`. (See the NSCoder class specification in the *Foundation Framework Reference* for more information on encoding objects for archiving or distribution.)

Code	Meaning
c	A <b>char</b>
i	An <b>int</b>
s	A <b>short</b>
l	A <b>long</b>
q	A <b>long long</b>
C	An <b>unsigned char</b>
I	An <b>unsigned int</b>
S	An <b>unsigned short</b>
L	An <b>unsigned long</b>
Q	An <b>unsigned long long</b>
f	A <b>float</b>
d	A <b>double</b>
v	A <b>void</b>
*	A character string ( <b>char *</b> )
@	An object (whether statically typed or typed <b>id</b> )
#	A class object (Class)
:	A method selector (SEL)
[ <i>arity type</i> ]	An array
{ <i>name= type...</i> }	A structure
( <i>type...</i> )	A union
<i>bnum</i>	A bit field of <i>num</i> bits
^ <i>type</i>	A pointer to <i>type</i>
?	An unknown type (among other things, this code is used for function pointers)

The type code for an array is enclosed within square brackets; the number of elements in the array is specified immediately after the open bracket, before the array type. For example, an array of 12 pointers to floats would be encoded as:

---

```
[12^f]
```

Structures are specified within braces, and unions within parentheses. The structure tag is listed first, followed by an equal sign and the codes for the fields of the structure listed in sequence. For example, this structure,

```
typedef struct example {  
    id anObject;  
    char *aString;  
    int anInt;  
} Example;
```

would be encoded like this:

```
{example=@*i}
```

The same encoding results whether the defined type name (`Example`) or the structure tag (`example`) is passed to `@encode()`. The encoding for a structure pointer carries the same amount of information about the structure's fields:

```
^{example=@*i}
```

However, another level of indirection removes the internal type specification:

```
^^{example}
```

Objects are treated like structures. For example, passing the `NSObject` class name to `@encode()` yields this encoding:

```
{NSObject=#}
```

The `NSObject` class declares just one instance variable, `isa`, of type `Class`.

**Note:** Although the `@encode()` directive doesn't return them, the run-time system uses these additional encodings for type qualifiers when they're used to declare methods in a protocol:

Code	Meaning
r	const
n	in
N	inout
o	out
O	bycopy
R	byref
V	oneway

*Chapter 4*

The Run-Time System



---

The Objective-C language defers as many decisions as it can from compile time and link time to run time. Whenever possible, it does things dynamically. This means that the language requires not just a compiler, but also a run-time system to execute the compiled code. The run-time system acts as a kind of operating system for the Objective-C language; it's what makes the language work.

Objective-C programs interact with the run-time system at three distinct levels:

- Through Objective-C source code. For the most part, the run-time system works automatically and behind the scenes. You use it just by writing and compiling Objective-C source code.

It's up to the compiler to produce the data structures that the run-time system requires and to arrange the run-time function calls that carry out language instructions. The data structures capture information found in class and category definitions and in protocol declarations; they include the class and protocol objects discussed earlier, as well as method selectors, instance variable templates, and other information distilled from source code. The principal run-time function is the one that sends messages, as described under "How Messaging Works" in Chapter 2. It's invoked by source-code message expressions.

- Through a method interface defined in the NSObject class. Every object inherits from the NSObject class, so every object has access to the methods it defines. Most NSObject methods interact with the run-time system.

Some of these methods simply query the system for information. The preceding chapters, for example, mentioned the class method, which asks an object to identify its class, `isKindOfClass:` and `isMemberOfClass:`, which test an object's position in the inheritance hierarchy, `respondToSelector:`, which checks whether an object can accept a particular message, `conformsToProtocol:`, which checks whether it conforms to a protocol, and `methodForSelector:`, which asks for the address of a method implementation. Methods like these give an object the ability to introspect about itself.

Other methods set the run-time system in motion. For example, `performSelector:` and its companions initiate messages, and `alloc` produces a new object properly connected to its class.

All these methods were mentioned in previous chapters and are described in detail in the NSObject class specification in the *Foundation Framework Reference*.

- Through direct calls to run-time functions. The run-time system has a public interface, consisting mainly of a set of functions. Many are functions that

duplicate what you get automatically by writing Objective-C code or what the NSObject class provides with a method interface. Others manipulate low-level run-time processes and data structures. These functions make it possible to develop other interfaces to the run-time system and produce tools that augment the development environment; they're not needed when programming in Objective-C.

However, a few of the run-time functions might on occasion be useful when writing an Objective-C program. These functions—such as `sel_getUid()`, which returns a method selector for a method name, and `objc_msgSend()`, which sends a message to an object—are defined in the Objective-C run time system described at various places in the text of this manual.

Because the NSObject class is at the root of all inheritance hierarchies, the methods it defines are inherited by all classes. Its methods therefore establish behaviors that are inherent to every instance and every class object. However, in a few cases, the NSObject class merely defines a framework for how something should be done; it doesn't provide all the necessary code itself.

For example, the NSObject class defines a `description` method that should return an NSString associated with the receiver. If you define a class of named objects, you must implement a `description` method to return the specific character string associated with the receiver. NSObject's version of the method can't know what that name will be, so it merely returns the class name as a default.

This chapter looks at three areas where the NSObject class provides a framework and defines conventions, but where you may need to write code to fill in the details:

- Allocating and initializing new instances of a class, and deallocating instances when they're no longer needed
- Forwarding messages to another object
- Dynamically loading new modules into a running program

Other conventions of the NSObject class are described in the NSObject class specification in the *Foundation Framework Reference*.

## Allocation and Initialization

It takes two steps to create an object in Objective-C. You must both:

- Dynamically allocate memory for the new object, and
- Initialize the newly allocated memory to appropriate values.

---

An object isn't fully functional until both steps have been completed. As discussed in Chapter 2, each step is accomplished by a separate method, but typically in a single line of code:

```
id anObject = [[Rectangle alloc] init];
```

Separating allocation from initialization gives you individual control over each step so that each can be modified independently of the other. The following sections look first at allocation and then at initialization, and discuss how they are in fact controlled and modified.

### Allocating Memory For Objects

In Objective-C, memory for new objects is allocated using class methods defined in the `NSObject` class. `NSObject` defines two principal methods for this purpose, `alloc` and `allocWithZone:`.

```
+ (id)alloc;  
+ (id)allocWithZone:(NSZone *)zone;
```

These methods allocate enough memory to hold all the instance variables for an object belonging to the receiving class. They don't need to be overridden and modified in subclasses.

### Initializing New Objects

The `alloc` and `allocWithZone:` methods initialize a new object's `isa` instance variable so that it points to the object's class (the class object). All other instance variables are set to 0. Usually, an object needs to be more specifically initialized before it can be safely used.

This initialization is the responsibility of class-specific instance methods that, by convention, begin with the abbreviation "init". If the method takes no arguments, the method name is just those four letters, `init`. If it takes arguments, labels for the arguments follow the "init" prefix. For example, an `NSView` can be initialized with an `initWithFrame:` method.

Every class that declares instance variables must provide an `init...` method to initialize them. The `NSObject` class declares the `isa` variable and defines an `init` method. However, since `isa` is initialized when memory for a new object is allocated, all `NSObject`'s `init` method does is return `self`. `NSObject` declares the method mainly to establish the naming convention described above.

### The Returned Object

An `init...` method normally initializes the instance variables of the receiver, then returns it. It's the responsibility of the method to return an object that can be used without error.

However, in some cases, this responsibility can mean returning a different object than the receiver. For example, if a class keeps a list of named objects, it might provide an `initWithName:` method to initialize new instances. If there can be no more than one object per name, `initWithName:` might refuse to assign the same name to two objects. When asked to assign a new instance a name that's already being used by another object, it might free the newly allocated instance and return the other object—thus ensuring the uniqueness of the name while at the same time providing what was asked for, an instance with the requested name.

In a few cases, it might be impossible for an `init...` method to do what it's asked to do. For example, an `initWithFile:` method might get the data it needs from a file passed as an argument. If the file name it's passed doesn't correspond to an actual file, it won't be able to complete the initialization. In such a case, the `init...` method could free the receiver and return `nil`, indicating that the requested object can't be created.

Because an `init...` method might return an object other than the newly allocated receiver, or even return `nil`, it's important that programs use the value returned by the initialization method, not just that returned by `alloc` or `allocWithZone:`. The following code is very dangerous, since it ignores the return of `init`.

```
id anObject = [SomeClass alloc];
[anObject init];
[anObject someOtherMessage];
```

It's recommended that you combine allocation and initialization messages:

```
id anObject = [[SomeClass alloc] init];
[anObject someOtherMessage];
```

If there's a chance that the `init...` method might return `nil`, the return value should be checked before proceeding:

---

```
id anObject = [[SomeClass alloc] init];
if ( anObject )
    [anObject someOtherMessage];
else
    . . .
```

## Arguments

An `init...` method must ensure that all of an object's instance variables have reasonable values. This doesn't mean that it needs to provide an argument for each variable. It can set some to default values or depend on the fact that (except for `isa`) all bits of memory allocated for a new object are set to 0. For example, if a class requires its instances to have a name and a data source, it might provide an `initWithName:fromFile:` method, but set nonessential instance variables to arbitrary values or allow them to have the null values set by default. It could then rely on methods like `setEnabled:`, `setFriend:`, and `setDimensions:` to modify default values after the initialization phase had been completed.

Any `init...` method that takes arguments must be prepared to handle cases where an inappropriate value is passed. One option is to substitute a default value, and to let a null argument explicitly evoke the default.

## Coordinating Classes

Every class that declares instance variables must provide an `init...` method to initialize them (unless the variables require no initialization). The `init...` methods the class defines initialize only those variables declared in the class. Inherited instance variables are initialized by sending a message to `super` to perform an initialization method defined somewhere farther up the inheritance hierarchy:

```
- initWithName:(char *)string
{
    if ( self = [super init] ) {
        name = (char *)NSZoneMalloc([self zone],
                                   strlen(string) + 1);
        strcpy(name, string);
        return self;
    }
    return nil;
}
```

The message to `super` chains together initialization methods in all inherited classes. Because it comes first, it ensures that superclass variables are initialized before those declared in subclasses. For example, a `Rectangle` object must be initialized as an `NSObject`, a `Graphic`, and a `Shape` before it's initialized as a

Rectangle. (See Chapter 2 for a figure illustrating the Rectangle inheritance hierarchy.)

The connection between the `initWithName:` method illustrated above and the inherited `init` method it incorporates is diagrammed in the figure below:

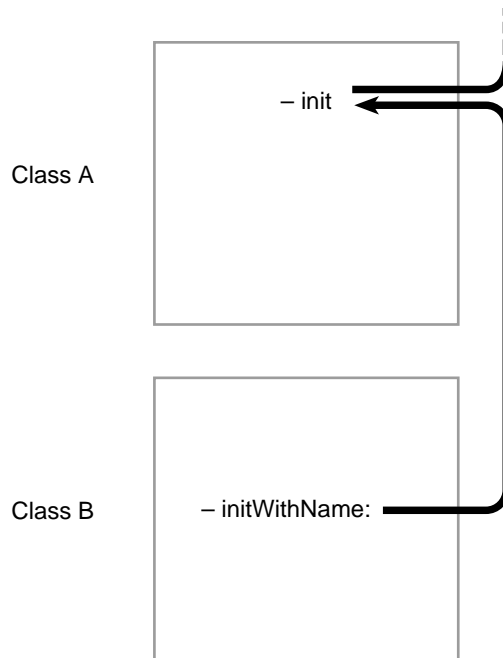

A class must also make sure that all inherited initialization methods work. For example, if class A defines an `init` method and its subclass B defines an `initWithName:` method, as shown in the figure above, B must also make sure that an `init` message will successfully initialize B instances. The easiest way to do that is to replace the inherited `init` method with a version that invokes `initWithName:`.

```
- init
{
    return [self initWithName:"default"];
}
```

The `initWithName:` method would, in turn, invoke the inherited method, as was shown in the example and figure above. That figure can be modified to include B's version of `init`, as shown below:

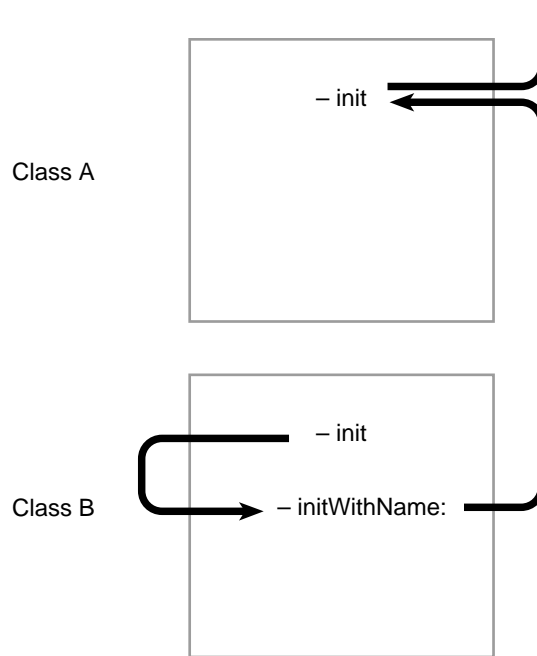

Covering inherited initialization methods makes the class you define more portable to other applications. If you leave an inherited method uncovered, someone else may use it to produce incorrectly initialized instances of your class.

### The Designated Initializer

In the example above, `initWithName:` would be the *designated initializer* for its class (class B). The designated initializer is the method in each class that guarantees inherited instance variables are initialized (by sending a message to `super` to perform an inherited method). It's also the method that does most of the work, and the one that other initialization methods in the same class invoke. It's an OPENSTEP convention that the designated initializer is always the method that allows the most freedom to determine the character of a new instance (the one with the most arguments).

It's important to know the designated initializer when defining a subclass. For example, suppose we define class C, a subclass of B, and implement an `initWithName:fromFile:` method. In addition to this method, we have to make sure that the inherited `init` and `initWithName:` methods also work for instances of C. This can be done just by covering B's `initWithName:` with a version that invokes `initWithName:fromFile:`.

```

- initWithName:(char *)string
{
    return [self initWithName:string fromFile:NULL];
}

```

For an instance of the C class, the inherited `init` method will invoke this new version of `initWithName:` which will invoke `initWithName:fromFile:`. The relationship between these methods is diagrammed below.

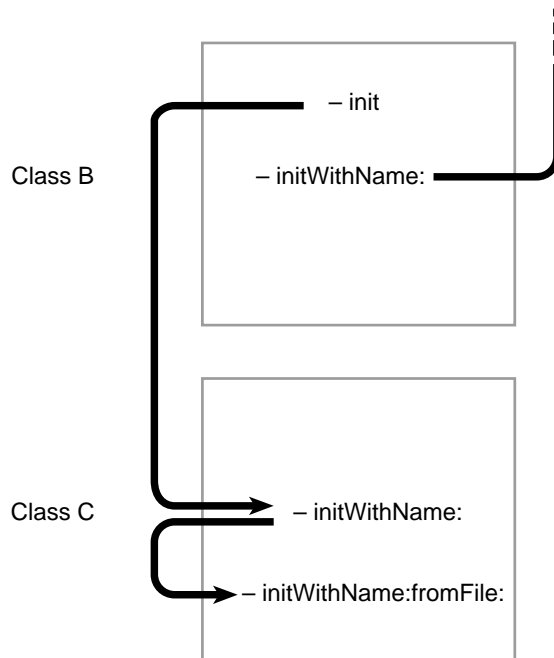

This figure omits an important detail. The `initWithName:fromFile:` method, being the designated initializer for the C class, will send a message to `super` to invoke an inherited initialization method. But which of B's methods should it invoke, `init` or `initWithName:`? It can't invoke `init`, for two reasons:

- Circularity would result (`init` invokes C's `initWithName:`, which invokes `initWithName:fromFile:`, which invokes `init` again).
- It won't be able to take advantage of the initialization code in B's version of `initWithName:`.

Therefore, `initWithName:fromFile:` must invoke `initWithName:`.

---

```
- initWithName:(char *)string fromFile:(char *)pathname
{
    if ( self = [super initWithName:string] )
        . . .
}
```

The general principle is this:

*The designated initializer in one class must, through a message to super, invoke the designated initializer in an inherited class.*

Designated initializers are chained to each other through messages to super, while other initialization methods are chained to designated initializers through messages to self.

The figure below shows how all the initialization methods in classes A, B, and C are linked. Messages to self are shown on the left and messages to super are shown on the right.

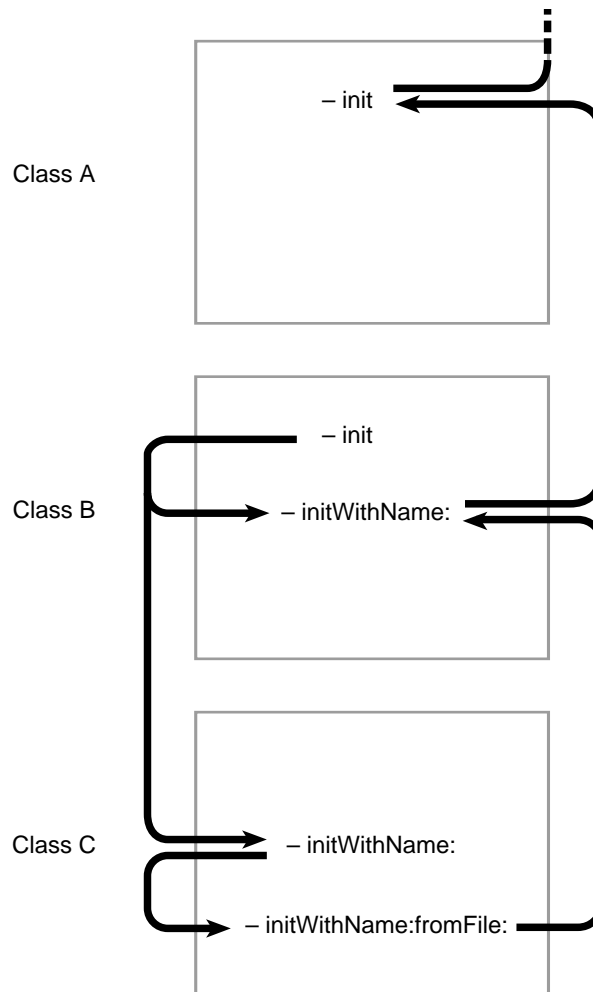

Note that B's version of `init` sends a message to self to invoke the `initWithName:` method. Therefore, when the receiver is an instance of the B class, it will invoke B's version of `initWithName:`, and when the receiver is an instance of the C class, it will invoke C's version.

#### Combining Allocation and Initialization

By convention, in OPENSTEP classes define creation methods that combine the two steps of allocating and initializing to return new, initialized instances of the class. These methods typically take the form `+ className...` where *className* is the name of the class. For instance, `NSString` has the following methods (among others):

---

```
+ (NSString *)stringWithCString:(const char *)bytes;
+ (NSString *)stringWithFormat:(NSString *)format, ...;
```

Similarly, NSArray defines the following class methods that combine allocation and initialization:

```
+ (id)array;
+ (id)arrayWithObject:(id)anObject;
+ (id)arrayWithObjects:(id)firstObj, ...;
```

Instances created with any of these methods will be deallocated automatically, so you don't have to release them unless you first retain them.

Methods that combine allocation and initialization are particularly valuable if the allocation must somehow be informed by the initialization. For example, if the data for the initialization is taken from a file, and the file might contain enough data to initialize more than one object, it would be impossible to know how many objects to allocate until the file is opened. In this case, you might implement a `listFromFile:` method that takes the name of the file as an argument. It would open the file, see how many objects to allocate, and create a List object large enough to hold all the new objects. It would then allocate and initialize the objects from data in the file, put them in the List, and finally return the List.

It also makes sense to combine allocation and initialization in a single method if you want to avoid the step of blindly allocating memory for a new object that you might not use. As mentioned under “The Returned Object” above, an `initWithName:` method might sometimes substitute another object for the receiver. For example, when `initWithName:` is passed a name that's already taken, it might free the receiver and in its place return the object that was previously assigned the name. This means, of course, that an object is allocated and freed immediately without ever being used.

If the code that checks whether the receiver should be initialized is placed inside the method that does the allocation instead of inside `initWithName:`, you can avoid the step of allocating a new instance when one isn't needed.

In the following example, the `soloist` method ensures that there's no more than one instance of the Soloist class. It allocates and initializes an instance only once:

```
+ soloist
{
    static Soloist *instance = nil;

    if ( instance == nil )
        instance = [[self alloc] init];
    return instance;
}
```

### Deallocation

The NSObject class defines a `dealloc` method that relinquishes the memory that was originally allocated for an object. You rarely invoke `dealloc` directly, however, because OPENSTEP provides a mechanism for the automatic disposal of objects (which makes use of `dealloc`). For more information on this automatic object disposal mechanism, see the introduction to the *Foundation Framework Reference*.

The purpose of a `dealloc` message is to deallocate all the memory occupied by the receiver. NSObject's version of the method deallocates the receiver's instance variables, but doesn't follow any variable that points to other memory. If the receiver allocated any additional memory—to store a character string or an array of structures, for example—that memory must also be deallocated (unless it's shared by other objects). Similarly, if the receiver is served by another object that would be rendered useless in its absence, that object must also be deallocated.

Therefore, it's necessary for subclasses to override NSObject's version of `dealloc` and implement a version that deallocates all of the other memory the object occupies. Every class that has its objects allocate additional memory must have its own `dealloc` method. Each version of `dealloc` ends with a message to `super` to perform an inherited version of the method, as illustrated in the following example:

```
- dealloc {
    [companion release];
    free(privateMemory);
    vm_deallocate(task_self(), sharedMemory, memorySize);
    [super dealloc];
}
```

By working its way up the inheritance hierarchy, every `dealloc` message eventually invokes NSObject's version of the of the method.

---

## Forwarding

It's an error to send a message to an object that can't respond to it. However, before announcing the error, the run-time system gives the receiving object a second chance to handle the message. It sends the object a `forwardInvocation:` message with an `NSInvocation` object as its sole argument—the `NSInvocation` object encapsulates the original message and the arguments that were passed with it.

You can implement a `forwardInvocation:` method to give a default response to the message, or to avoid the error in some other way. As its name implies, `forwardInvocation:` is commonly used to forward the message to another object.

To see the scope and intent of forwarding, imagine the following scenarios: Suppose, first, that you're designing an object that can respond to a `negotiate` message, and you want its response to include the response of another kind of object. You could accomplish this easily by passing a `negotiate` message to the other object somewhere in the body of the `negotiate` method you implement.

Take this a step further, and suppose that you want your object's response to a `negotiate` message to be exactly the response implemented in another class. One way to accomplish this would be to make your class inherit the method from the other class. However, it might not be possible to arrange things this way. There may be good reasons why your class and the class that implements `negotiate` are in different branches of the inheritance hierarchy.

Even if your class can't inherit the `negotiate` method, you can still “borrow” it by implementing a version of the method that simply passes the message on to an instance of the other class:

```
- negotiate
{
    if ( [someOtherObject respondsToSelector:@selector(negotiate)] )
        return [someOtherObject negotiate];
    return self;
}
```

This way of doing things could get a little cumbersome, especially if there were a number of messages you wanted your object to pass on to the other object. You'd have to implement one method to cover each method you wanted to borrow from the other class. Moreover, it would be impossible to handle cases where you didn't know, at the time you wrote the code, the full set of messages that you might want to forward. That set might depend on events at run time, and it might change as new methods and classes are implemented in the future.

The second chance offered by a `forwardInvocation:` message provides a less ad hoc solution to this problem, and one that's dynamic rather than static. It works like this: When an object can't respond to a message because it doesn't have a method matching the selector in the message, the run-time system informs the object by sending it a `forwardInvocation:` message. Every object inherits a `forwardInvocation:` method from the `NSObject` class. However, `NSObject`'s version of the method simply invokes `doesNotRecognizeSelector:` due to the unrecognized message. By overriding `NSObject`'s version and implementing your own, you can take advantage of the opportunity that the `forwardInvocation:` message provides to forward messages to other objects.

To forward a message, all a `forwardInvocation:` method needs to do is:

- Determine where the message should go, and
- Send it there with its original arguments.

The message can be sent with the `invokeWithTarget:` method:

```
- (void)forwardInvocation:(NSInvocation *)anInvocation
{
    if ([someOtherObject respondsToSelector:
        [anInvocation selector]])
        [anInvocation invokeWithTarget:someOtherObject];
    else
        [self doesNotRecognizeSelector:[anInvocation selector]];
}
```

The return value of the message that's forwarded is returned to the original sender. All types of return values can be delivered to the sender, including `ids`, structures, and double-precision floating point numbers.

A `forwardInvocation:` method can act as a distribution center for unrecognized messages, parceling them out to different receivers. Or it can be a transfer station, sending all messages to the same destination. It can translate one message into another, or simply "swallow" some messages so there's no response and no error. A `forwardInvocation:` method can also consolidate several messages into a single response. What `forwardInvocation:` does is up to the implementor. However, the opportunity it provides for linking objects in a forwarding chain opens up possibilities for program design.

Note: The `forwardInvocation:` method gets to handle messages only if they don't invoke an existing method in the nominal receiver. If, for example, you want your object to forward `negotiate` messages to another object, it can't have a `negotiate` method of its own. If it does, the message will never reach `forwardInvocation:`.

---

For more information on forwarding and invocations, see the `NSInvocation` class specification in the *Foundation Framework Reference*.

### Forwarding and Multiple Inheritance

Forwarding mimics inheritance, and can be used to lend some of the effects of multiple inheritance to Objective-C programs. As shown in the figure below, an object that responds to a message by forwarding it appears to borrow or “inherit” a method implementation defined in another class.

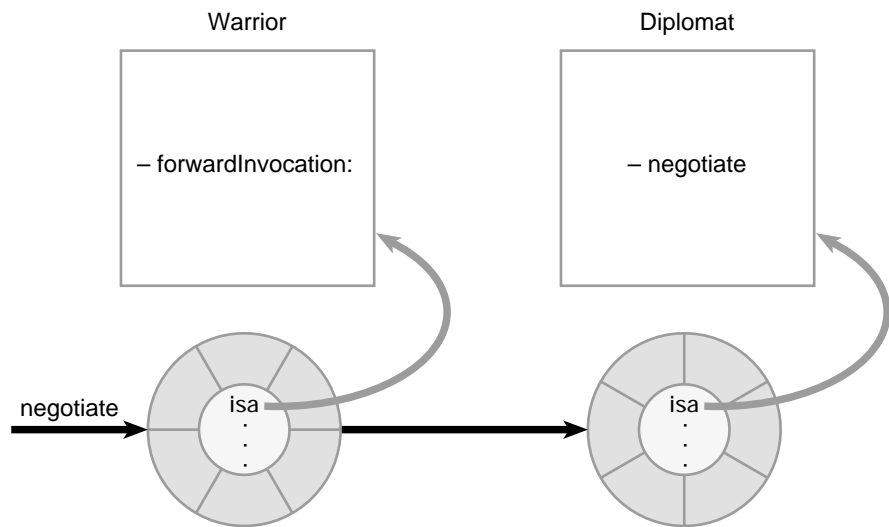

In this illustration, an instance of the `Warrior` class forwards a `negotiate` message to an instance of the `Diplomat` class. The `Warrior` will appear to negotiate like a `Diplomat`. It will seem to respond to the `negotiate` message, and for all practical purposes it does respond (although it’s really a `Diplomat` that’s doing the work).

The object that forwards a message thus “inherits” methods from two branches of the inheritance hierarchy—its own branch and that of the object that responds to the message. In the example above, it will appear as if the `Warrior` class inherits from `Diplomat` as well as its own superclass.

Forwarding addresses most needs that lead programmers to value multiple inheritance. However, there’s an important difference between the two: Multiple inheritance combines different capabilities in a single object. It tends toward large, multifaceted objects. Forwarding, on the other hand, assigns separate responsibilities to separate objects. It decomposes problems into smaller objects, but associates those objects in a way that’s transparent to the message sender.

### Surrogate Objects

Forwarding not only mimics multiple inheritance, it also makes it possible to develop lightweight objects that represent or “cover” more substantial objects. The surrogate stands in for the other object and funnels messages to it.

The proxy discussed under “Remote Messaging” in Chapter 3 is such an object. A proxy takes care of the administrative details of forwarding messages to a remote receiver, making sure argument values are copied and retrieved across the connection, and so on. But it doesn’t attempt to do much else; it doesn’t duplicate the functionality of the remote object but simply gives the remote object a local address, a place where it can receive messages in another application.

Other kinds of surrogate objects are also possible. Suppose, for example, that you have an object that manipulates a lot of data—perhaps it creates a complicated image or reads the contents of a file on disk. Setting this object up could be time-consuming, so you prefer to do it lazily—when it’s really needed or when system resources are temporarily idle. At the same time, you need at least a placeholder for this object in order for the other objects in the application to function properly.

In this circumstance, you could initially create, not the full-fledged object, but a lightweight surrogate for it. This object could do some things on its own, such as answer questions about the data, but mostly it would just hold a place for the larger object and, when the time came, forward messages to it. When the surrogate’s `forwardInvocation:` method first receives a message destined for the other object, it would check to be sure that the object existed and would create it if it didn’t. All messages for the larger object go through the surrogate, so as far as the rest of the program is concerned, the surrogate and the larger object would be the same.

### Making Forwarding Transparent

Although forwarding mimics inheritance, the `NSObject` class never confuses the two. Methods like `respondToSelector:` and `isKindOfClass:` look only at the inheritance hierarchy, never at the forwarding chain. If, for example, a `Warrior` object is asked whether it responds to a `negotiate` message,

```
if ( [aWarrior respondsToSelector:@selector(negotiate)] )  
    . . .
```

---

the answer will be NO, even though it can receive `negotiate` messages without error and respond to them, in a sense, by forwarding them to a `Diplomat`. (See the previous figure.)

In many cases, NO is the right answer. But it may not be. If you use forwarding to set up a surrogate object or to extend the capabilities of a class, the forwarding mechanism should probably be as transparent as inheritance. If you want your objects to act as if they truly inherited the behavior of the objects they forward messages to, you'll need to re-implement the `respondsToSelector:` and `isKindOfClass:` methods to include your forwarding algorithm:

```
- (BOOL)respondsToSelector:(SEL)aSelector
{
    if ( [super respondsToSelector:aSelector] )
        return YES;
    else {
        /* Here, test whether the aSelector message can
         * be forwarded to another object and whether that
         * object can respond to it. Return YES if it can. */
    }
    return NO;
}
```

In addition to `respondsToSelector:` and `isKindOfClass:`, the `instancesRespondToSelector:` method should also mirror the forwarding algorithm. This method rounds out the set. If protocols are used, the `conformsToProtocol:` method should likewise be added to the list. Similarly, if an object forwards any remote messages it receives, it should have a version of `methodSignatureForSelector:` that can return accurate descriptions of the methods that ultimately respond to the forwarded messages.

You might consider putting the forwarding algorithm somewhere in private code and have all these methods, `forwardInvocation:` included, call it.

Note: The methods mentioned above are described in the `NSObject` class specification in the *Foundation Framework Reference*. For information on `invokeWithTarget:`, see the `NSInvocation` class specification in the *Foundation Framework Reference*.

## Dynamic Loading

An Objective-C program can load and link new classes and categories while it's running. The new code is incorporated into the program and treated identically to classes and categories loaded at the start.

Dynamic loading can be used to do a lot of different things. For example, device drivers are dynamically loaded into the kernel. Adaptors for database servers are dynamically loaded by the Enterprise Objects™ Framework.

In the OpenStep environment, dynamic loading is commonly used to allow applications to be customized. Others can write modules that your program will load at run time—much as Interface Builder loads custom palettes, OPENSTEP for Mach's Preferences application loads custom displays, and its Workspace Manager loads data inspectors. The loadable modules extend what your application can do. They contribute to it in ways that you permit, but could not have anticipated or defined yourself. You provide the framework, but others provide the code.

Although there are run-time functions that enable dynamic loading (`objc_loadModules()` and `objc_unloadModules()`, defined in `objc/objc-load.h`), OPENSTEP's `NSBundle` class provides a significantly more convenient interface for dynamic loading—one that's object-oriented and integrated with related services. See the `NSBundle` class specification in the *Foundation Framework Reference* for information on the `NSBundle` class and its use.

*Appendix A*

## Objective-C Language Summary



---

Objective-C adds a small number of constructs to the C language and defines a handful of conventions for effectively interacting with the run-time system. This appendix lists all the additions to the language, but doesn't go into great detail. For more information, see Chapter 2 and Chapter 3 of this manual. For a more formal presentation of Objective-C syntax, see Appendix B, "Reference Manual for the Objective-C Language," which follows this summary.

## Messages

Message expressions are enclosed in square brackets:

```
[receiver message]
```

The *receiver* can be:

- A variable or expression that evaluates to an object (including the variable `self`)
- A class name (indicating the class object)
- `super` (indicating an alternative search for the method implementation)

The *message* is the name of a method plus any arguments passed to it.

## Defined Types

The principal types used in Objective-C are defined in `objc/objc.h`. They are:

Type	Definition
<code>id</code>	An object (a pointer to its data structure)
<code>Class</code>	A class object (a pointer to the class data structure)
<code>SEL</code>	A selector, a compiler-assigned code that identifies a method name
<code>IMP</code>	A pointer to a method implementation that returns an <code>id</code>
<code>BOOL</code>	A boolean value, either YES or NO

`id` can be used to type any kind of object, class, or instance. In addition, class names can be used as type names to statically type instances of a class. A statically typed instance is declared to be a pointer to its class or to any class it inherits from.

The `objc.h` header file also defines these useful terms:

Term	Definition
<code>nil</code>	A null object pointer, <code>(id)0</code>
<code>Nil</code>	A null class pointer, <code>(Class)0</code>

## Preprocessor Directives

The preprocessor understands these new notations:

Notation	Definition
<code>#import</code>	Imports a header file. This directive is identical to <code>#include</code> , except that it won't include the same file more than once.
<code>//</code>	Begins a comment that continues to the end of the line.

## Compiler Directives

Directives to the compiler begin with “@”. The following directives are used to declare and define classes, categories, and protocols:

---

Directive	Definition
@interface	Begins the declaration of a class or category interface
@implementation	Begins the definition of a class or category
@protocol	Begins the declaration of a formal protocol
@end	Ends the declaration/definition of a class, category, or protocol

The following mutually-exclusive directives specify the visibility of instance variables:

Directive	Definition
@private	Limits the scope of an instance variable to the class that declares it
@protected	Limits instance variable scope to declaring and inheriting classes
@public	Removes restrictions on the scope of instance variables

The default is @protected.

In addition, there are directives for these particular purposes:

Directive	Definition
@class	Declares the names of classes defined elsewhere
@selector( <i>method</i> )	Returns the compiled selector that identifies <i>method</i>
@protocol( <i>name</i> )	Returns the <i>name</i> protocol (an instance of the Protocol class)
@encode( <i>spec</i> )	Yields a character string that encodes the type structure of <i>spec</i>
@defs( <i>classname</i> )	Yields the internal data structure of <i>classname</i> instances

## Classes

A new class is declared with the `@interface` directive. It imports the interface file for its superclass:

```
#import "ItsSuperclass.h"

@interface ClassName : ItsSuperclass < protocol list >
{
    instance variable declarations
}
method declarations
@end
```

Everything but the compiler directives and class name is optional. If the colon and superclass name are omitted, the class is declared to be a new root class. If any protocols are listed, the header files where they're declared must also be imported.

A class definition imports its own interface:

```
#import "ClassName.h"

@implementation ClassName
method definitions
@end
```

## Categories

A category is declared in much the same way as a class. It imports the interface file that declares the class:

```
#import "ClassName.h"

@interface ClassName ( CategoryName ) < protocol list >
method declarations
@end
```

The protocol list and method declarations are optional. If any protocols are listed, the header files where they're declared must also be imported.

---

Like a class definition, a category definition imports its own interface:

```
#import "CategoryName.h"

@implementation ClassName ( CategoryName )
method definitions
@end
```

## Formal Protocols

Formal protocols are declared using the `@protocol` directive:

```
@protocol ProtocolName < protocol list >
method declarations
@end
```

The list of incorporated protocols and the method declarations are optional. The protocol must import the header files that declare any protocols it incorporates.

Within source code, protocols are referred to using the similar `@protocol()` directive, where the parentheses enclose the protocol name.

Protocol names listed within angle brackets (<...>) are used to do three different things:

- In a protocol declaration, to incorporate other protocols (as shown above)
- In a class or category declaration, to adopt the protocol (as shown under “Classes” and “Categories” above)
- In a type specification, to limit the type to objects that conform to the protocol

Within protocol declarations, these type qualifiers support remote messaging:

Type Qualifier	Definition
oneway	The method is for asynchronous messages and has no valid return.
in	The argument passes information to the remote receiver.
out	The argument gets information returned by reference.
inout	The argument both passes information and gets information.
bycopy	A copy of the object, not a proxy, should be passed or returned.
byref	A reference to the object, not a copy, should be passed or returned.

## Method Declarations

The following conventions are used in method declarations:

- A “+” precedes declarations of class methods.
- A “-” precedes declarations of instance methods.
- Arguments are declared after colons (:). Typically, a label describing the argument precedes the colon. Both labels and colons are considered part of the method name.
- Argument and return types are declared using the C syntax for type casting.
- The default return and argument type for methods is `id`, not `int` as it is for functions. (However, the modifier `unsigned` when used without a following type always means `unsigned int`)

## Method Implementations

Each method implementation is passed two hidden arguments:

- The receiving object (`self`)
- The selector for the method (`_cmd`)

Within the implementation, both `self` and `super` refer to the receiving object. `super` replaces `self` as the receiver of a message to indicate that only methods inherited by the implementation should be performed in response to the message.

---

Methods with no other valid return typically return `void`.

## Naming Conventions

The names of files that contain Objective-C source code have a “.m” extension. Files that declare class and category interfaces or that declare protocols have the “.h” extension typical of header files.

Class, category, and protocol names generally begin with an uppercase letter; the names of methods and instance variables typically begin with a lowercase letter. The names of variables that hold instances usually also begin with lowercase letters.

In Objective-C, identical names that serve different purposes don't clash. Within a class, names can be freely assigned:

- A class can declare methods with the same names as methods in other classes.
- A class can declare instance variables with the same names as variables in other classes.
- An instance method can have the same name as a class method.
- A method can have the same name as an instance variable.

Likewise, protocols and categories of the same class have protected name spaces:

- A protocol can have the same name as a class, a category, or anything else.
- A category of one class can have the same name as a category of another class.

However, class names are in the same name space as variables and defined types. A program can't have a global variable with the same name as a class.



*Appendix B*

---

Reference Manual for the Objective-C  
Language



---

This appendix presents a formal grammar for the Objective-C extensions to the C language—as the Objective-C language is implemented for the OPENSTEP development environment. It adds to the grammar for ANSI standard C found in Appendix A of *The C Programming Language* (second edition, 1988) by Brian W. Kernighan and Dennis M. Ritchie, published by Prentice Hall, and should be read in conjunction with that book.

The Objective-C extensions introduce some new symbols (such as *class-interface*), but also make use of symbols (such as *function-definition*) that are explained in the standard C grammar. The symbols mentioned but not explained here are listed below:

Undefined Symbols	
compound statement	identifier
constant	parameter-type-list
declaration	string
declaration-list	struct-declaration-list
enum-specifier	struct-or-union
expression	typedef-name
function-definition	type-name

Of these, *identifier* and *string* are undefined terminal symbols. Objective-C adds no undefined terminal symbols of its own.

Two notational conventions used here differ from those used in *The C Programming Language*:

- Literal symbols are shown in **bold type**.
- Brackets enclose optional elements and are in *italic type*. Literal brackets, like other literal symbols, are non-italic and bold.

Otherwise, this appendix follows the conventions of the C reference manual. Each part of the grammar consists of a symbol followed by a colon and an indented list of mutually-exclusive possibilities for expanding the symbol. For example:

*receiver*:  
*expression*

*class-name*  
*super*

However, there is an exception: Even though they're not mutually exclusive, the constituents of classes, categories, and protocols are listed on separate lines to clearly show the ordering of elements. For example:

```
protocol-declaration:
@protocol protocol-name
[ protocol-reference-list ]
[ interface-declaration-list ]
@end
```

This exception to the general rule is easily recognized since each list terminates with `@end`.

There are just four entry points where the Objective-C language modifies the rules defined for standard C:

- External declarations
- Type specifiers
- Type qualifiers
- Primary expressions

This appendix is therefore divided into four sections corresponding to these points. Where a rule in the standard C grammar is modified by an Objective-C extension, the entire rule is repeated in its modified form.

## External Declarations

```
external-declaration:
function-definition
declaration
class-interface
class-implementation
category-interface
category-implementation
protocol-declaration
class-declaration-list
```

```
class-interface:
@interface class-name [ : superclass-name ]
[ protocol-reference-list ]
```

---

*[ instance-variables ]*  
*[ interface-declaration-list ]*  
*@end*

*class-implementation:*  
*@implementation class-name [ : superclass-name ]*  
*[ instance-variables ]*  
*[ implementation-definition-list ]*  
*@end*

*category-interface:*  
*@interface class-name ( category-name )*  
*[ protocol-reference-list ]*  
*[ interface-declaration-list ]*  
*@end*

*category-implementation:*  
*@implementation class-name ( category-name )*  
*[ implementation-definition-list ]*  
*@end*

*protocol-declaration:*  
*@protocol protocol-name*  
*[ protocol-reference-list ]*  
*[ interface-declaration-list ]*  
*@end*

*class-declaration-list:*  
*@class class-list ;*

*class-list:*  
*class-name*  
*class-list , class-name*

*protocol-reference-list:*  
*< protocol-list >*

*protocol-list:*  
*protocol-name*  
*protocol-list , protocol-name*

*class-name:*  
*identifier*

*superclass-name:*  
*identifier*

*category-name:*  
*identifier*

*protocol-name:*  
*identifier*

*instance-variables:*  
{ [ *visibility-specification* ] *struct-declaration-list* [ *instance-variables* ] }

*visibility-specification:*  
*@private*  
*@protected*  
*@public*

*interface-declaration-list:*  
*declaration*  
*method-declaration*  
*interface-declaration-list declaration*  
*interface-declaration-list method-declaration*

*method-declaration:*  
*class-method-declaration*  
*instance-method-declaration*

*class-method-declaration:*  
+ [ *method-type* ] *method-selector* ;

*instance-method-declaration:*  
- [ *method-type* ] *method-selector* ;

*implementation-definition-list:*  
*function-definition*  
*declaration*  
*method-definition*  
*implementation-definition-list function-definition*  
*implementation-definition-list declaration*  
*implementation-definition-list method-definition*

*method-definition:*  
*class-method-definition*  
*instance-method-definition*

*class-method-definition:*  
+ [ *method-type* ] *method-selector* [ *declaration-list* ] *compound-statement*

---

*instance-method-definition:*  
- [ *method-type* ] *method-selector* [ *declaration-list* ] *compound-statement*

*method-selector:*  
*unary-selector*  
*keyword-selector* [ , ... ]  
*keyword-selector* [ , *parameter-type-list* ]

*unary-selector:*  
*selector*

*keyword-selector:*  
*keyword-declarator*  
*keyword-selector* *keyword-declarator*

*keyword-declarator:*  
: [ *method-type* ] *identifier*  
*selector* : [ *method-type* ] *identifier*

*selector:*  
*identifier*

*method-type:*  
( *type-name* )

## Type Specifiers

*type-specifier:*  
**void**  
**char**  
**short**  
**int**  
**long**  
**float**  
**double**  
**signed**  
**unsigned**  
*id* [ *protocol-reference-list* ]  
*class-name* [ *protocol-reference-list* ]  
*struct-or-union-specifier*  
*enum-specifier*  
*typedef-name*

*struct-or-union-specifier:*  
*struct-or-union* [ *identifier* ] { *struct-declaration-list* }  
*struct-or-union* [ *identifier* ] { @defs ( *class-name* ) }  
*struct-or-union* *identifier*

## Type Qualifiers

*type-qualifier:*  
const  
volatile  
*protocol-qualifier*

*protocol-qualifier:*  
in  
out  
inout  
bycopy  
byref  
oneway

## Primary Expressions

*primary-expression:*  
*identifier*  
*constant*  
*string*  
( *expression* )  
self  
*message-expression*  
*selector-expression*  
*protocol-expression*  
*encode-expression*

*message-expression:*  
[ *receiver* *message-selector* ]

*receiver:*  
*expression*  
*class-name*  
super

---

*message-selector:*  
*selector*  
*keyword-argument-list*

*keyword-argument-list:*  
*keyword-argument*  
*keyword-argument-list keyword-argument*

*keyword-argument:*  
*selector : expression*  
*: expression*

*selector-expression:*  
*@selector ( selector-name )*

*selector-name:*  
*selector*  
*keyword-name-list*

*keyword-name-list:*  
*keyword-name*  
*keyword-name-list keyword-name*

*keyword-name:*  
*selector :*  
*:*

*protocol-expression:*  
*@protocol ( protocol-name )*

*encode-expression:*  
*@encode ( type-name )*



---

## Glossary

**abstract class** A class that's defined solely so that other classes can inherit from it. Programs don't use instances of an abstract class, only of its subclasses.

**abstract superclass** Same as *abstract class*.

**action message** In the Application Kit, a message sent by an object (such as an NSButton or NSSlider) in response to a user action (such as clicking the button or dragging the slider's knob). The message translates the user's action into a specific instruction for the application. See also *target*.

**active application** The application associated with keyboard events, the one the user is currently working in. On Mach, menus are visible on-screen only for the active application, and only the active application can have the current key window.

**adopt** In the Objective-C language, a class is said to adopt a protocol if it declares that it implements all the methods in the protocol. Protocols are adopted by listing their names between angle brackets in a class or category declaration.

**anonymous object** An object of unknown class. The interface to an anonymous object is published through a protocol declaration.

**Application Kit** The Objective-C classes and C functions available for implementing the window-based user interface in an application. The Application Kit provides a basic program structure for applications that draw on the screen and respond to events. The Application Kit is packaged as a *framework*.

**archiving** The process of preserving a data structure, especially an object, for later use. An archived data structure is usually stored in a file, but it can also be written to memory, copied to the pasteboard, or sent to another application. In OpenStep, archiving involves writing data to an NSData object.

**asynchronous message** A remote message that returns immediately, without waiting for the application that receives the message to respond. The sending application and the receiving application act independently, and are therefore not "in sync." See also *synchronous message*.

**category** In the Objective-C language, a set of method definitions that is segregated from the rest of the class definition. Categories can be used to split a class definition into parts or to add methods to an existing class.

**class** In the Objective-C language, a prototype for a particular kind of object. A class definition declares instance variables and defines methods for all members of the class. Objects that have the same types of instance variables and have access to the same methods belong to the same class. See also *class object*.

**class method** In the Objective-C language, a method that can be used by the class object rather than by instances of the class.

**class object** In the Objective-C language, an object that represents a class and knows how to create new instances of the class. Class objects are created by the compiler, lack instance variables, and can't be statically typed, but otherwise behave like all other objects. As the receiver in a message expression, a class object is represented by the class name.

**compile time** The time when source code is compiled. Decisions made at compile time are constrained by the amount and kind of information encoded in source files.

**conform** In the Objective-C language, a class is said to conform to a protocol if it adopts the protocol or inherits from a class that adopts it. An instance conforms to a protocol if its class does. Thus, an instance that conforms to a protocol can perform any of the instance methods declared in the protocol.

**content view** In the Application Kit, the NSView object that's associated with the content area of a window—all the area in the window excluding the title bar, resize bar, and border. All other NSViews in the window are arranged in a hierarchy beneath the content view.

**controls** Graphical objects—such as buttons, sliders, text fields, and scrollers—that the user can operate to give instructions to an application.

**cursor** The small image (usually an arrow) that moves on the screen and is controlled by moving the mouse.

---

**delegate** An object that acts on behalf of another object.

**designated initializer** The `init...` method that has primary responsibility for initializing new instances of a class. Each class defines or inherits its own designated initializer. Through messages to `self`, other `init...` methods in the same class directly or indirectly invoke the designated initializer, and the designated initializer, through a message to `super`, invokes the designated initializer of its superclass.

**dynamic binding** Binding a method to a message—that is, finding the method implementation to invoke in response to the message—at run time, rather than at compile time.

**dynamic typing** Discovering the class of an object at run time rather than at compile time.

**event** The direct or indirect report of external activity, especially user activity on the keyboard and mouse.

**event message** In the Application Kit, a message to perform a method named after an event or sub-event. Event messages are used to dispatch events to the objects that will respond to them. See also *action message*.

**factory** Same as *class object*.

**factory method** Same as *class method*.

**factory object** Same as *class object*.

**file package** A directory that is presented as a file, allowing the user to manipulate a group of files as if they were one file. A file package for an application executable has the same name as the executable file, plus a “.app” extension. File packages for documents and bundles bear an extension that’s recognized as belonging to a particular application.

**formal protocol** In the Objective-C language, a protocol that’s declared with the `@protocol` directive. Classes can adopt formal protocols, objects can respond at run time when asked if they conform to a formal protocol, and instances can be typed by the formal protocols they conform to.

**framework** A way to package a logically-related set of classes, protocols and functions together with localized strings, on-line documentation, and other pertinent

files. OPENSTEP provides the Foundation framework and the Application Kit framework, among others. Frameworks are sometimes referred to as “kits.”

**id** In the Objective-C language, the general type for any kind of object regardless of class. `id` is defined as a pointer to an object data structure. It can be used for both class objects and instances of a class.

**informal protocol** In the Objective-C language, a protocol declared as a category, usually as a category of the `NSObject` class. The language gives explicit support to formal protocols, but not to informal ones.

**inheritance** In object-oriented programming, the ability of a superclass to pass its characteristics (methods and instance variables) on to its subclasses.

**inheritance hierarchy** In object-oriented programming, the hierarchy of classes that’s defined by the arrangement of superclasses and subclasses. Every class (except root classes such as `NSObject`) has a superclass, and any class may have an unlimited number of subclasses. Through its superclass, each class inherits from those above it in the hierarchy.

**instance** In the Objective-C language, an object that belongs to (is a member of) a particular class. Instances are created at run time according to the specification in the class definition.

**instance method** In the Objective-C language, any method that can be used by an instance of a class rather than by the class object.

**instance variable** In the Objective-C language, any variable that’s part of the internal data structure of an instance. Instance variables are declared in a class definition and become part of all objects that are members of or inherit from the class.

**Interface Builder** A tool that lets you graphically specify your application’s user interface. It sets up the corresponding objects for you and makes it easy for you to establish connections between these objects and your own code where needed.

**introspection** The ability of an object to reveal information about itself as an object—such as its class

and superclass, the messages it can respond to, and the protocols it conforms to.

**key window** The window in the active application that receives keyboard events and is the focus of user activity.

**link time** The time when files compiled from different source modules are linked into a single program. Decisions made by the linker are constrained by the compiled code and ultimately by the information contained in source code.

**localize** To adapt an application to work under various local conditions—especially to have it use a language selected by the user. Localization entails freeing application code from language-specific and culture-specific references and making it able to import localized resources (such as character strings, images, and sounds). For example, an application localized in Spanish would display “Salir” as the last item in the main menu. In Italian, it would be “Esci,” in German “Verlassen,” and in English “Quit.”

**main event loop** The principal control loop for applications that are driven by events. From the time it’s launched until the moment it’s terminated, an application gets one keyboard or mouse event after another from the Window Server and responds to them, waiting between events if the next event isn’t ready. In the Application Kit, the `NSApplication` object runs the main event loop.

**menu** A small window that displays a list of commands. Only menus for the active application are visible on-screen.

**message** In object-oriented programming, the method selector (name) and accompanying arguments that tell the receiving object in a message expression what to do.

**message expression** In object-oriented programming, an expression that sends a message to an object. In the Objective-C language, message expressions are enclosed within square brackets and consist of a receiver followed by a message (method selector and arguments).

**method** In object-oriented programming, a procedure that can be executed by an object.

**modal event loop** A temporary event loop that’s set up to get events directly from the event queue, bypassing the main event loop. Typically, a mouse-down event initiates the modal loop and the following mouse-up event ends it. The loop gets mouse-dragged events (or mouse-entered and mouse-exited events) to track the cursor’s movement while the user holds the mouse button down.

**multiple inheritance** In object-oriented programming, the ability of a class to have more than one superclass—to inherit from different sources and thus combine separately-defined behaviors in a single class. Objective-C doesn’t support multiple inheritance.

**name space** A logical subdivision of a program within which all names must be unique. Symbols in one name space won’t conflict with identically named symbols in another name space. For example, in Objective-C, the instance methods of each class are in a separate name space, as are the class methods and instance variables

**OPENSTEP** A set of frameworks, including Foundation and the Application Kit. NeXT also includes an application development and user environment, consisting of the Workspace Manager, the Window Server, Project Builder and Interface Builder, and other software.

**nib file** A file (actually a file package) that stores the specifications for all or part of an application’s interface. Nib files are created using Interface Builder and can contain archived objects, information about connections between objects, and sound and image data.

**nil** In the Objective-C language, an object id with a value of 0.

**object** A programming unit that groups together a data structure (instance variables) and the operations (methods) that can use or affect that data. Objects are the principal building blocks of object-oriented programs.

**outlet** An instance variable that points to another object. Outlet instance variables are a way for an object to keep track of the other objects to which it may need to send messages.

---

**panel** A window that holds objects that control what happens in other windows (such as a Font panel) or in the application generally (such as a Preferences panel), or a window that presents information about the application to the user (such as an information panel). See also *attention panel*.

**polymorphism** In object-oriented programming, the ability of different objects to respond, each in its own way, to the same message.

**pop-up list** A menu-like list of items that appears over (or next to) an on-screen button when the button is pressed. The user can choose an item by dragging to it and releasing the mouse button. When the mouse button is released, the pop-up list disappears.

**procedural programming language** A language, like C, that organizes a program as a set of procedures that have definite beginnings and ends.

**protocol** In the Objective-C language, the declaration of a group of methods not associated with any particular class. See also *formal protocol* and *informal protocol*.

**receiver** In object-oriented programming, the object that is sent a message.

**remote message** A message sent from one application to an object in another application.

**remote object** An object in another application, one that's a potential receiver for a remote message.

**run time** The time after a program is launched and while it's running. Decisions made at run time can be influenced by choices the user makes.

**selector** In the Objective-C language, the name of a method when it's used in a source-code message to an object, or the unique identifier that replaces the name when the source code is compiled. Compiled selectors are of type SEL.

**static typing** In the Objective-C language, giving the compiler information about what kind of object an instance is, by typing it as a pointer to a class.

**subclass** In the Objective-C language, any class that's one step below another class in the inheritance hierarchy. Occasionally used more generally to mean any class that inherits from another class, and

sometimes also used as a verb to mean the process of defining a subclass of another class.

**superclass** In the Objective-C language, a class that's one step above another class in the inheritance hierarchy; the class through which a subclass inherits methods and instance variables.

**surrogate** An object that stands in for and forwards messages to another object.

**synchronous message** A remote message that doesn't return until the receiving application finishes responding to the message. Because the application that sends the message waits for an acknowledgment or return information from the receiving application, the two applications are kept "in sync." See also *asynchronous message*.

**target** In the Application Kit, the object that receives action messages from an NSControl.

**typed stream** A specialized data stream used for archiving. When a typed stream is used, the type of the data is archived along with the data and an object's class hierarchy and version are archived with the object. See also *archiving*.

**Window Server** A process that dispatches user events to applications and renders PostScript code on behalf of applications.

**zone** A particular region of dynamic memory. Zones are set up in program code and are passed to allocation methods and functions to specify that the allocated memory should come from a particular zone. Allocating related data structures from the same zone can improve locality of reference and overall system performance.



---

INDEX

**Symbols**

`#import` directive 70, 153  
`//` comment marker 153  
`@class` directive 71, 154, 164  
`@defs()` directive 119, 154, 167  
`@encode()` directive 120–122, 154, 168  
`@end` directive 68, 154, 163, 164  
`@implementation` directive 72, 153, 155, 156, 164  
`@interface` directive 68, 153, 155, 163, 164  
`@private` directive 76–78, 154, 165  
`@protected` directive 76–78, 154, 165  
`@protocol` directive 102, 153, 156, 164  
`@protocol()` directive 104, 154, 156, 168  
`@public` directive 76–78, 154, 165  
`@selector()` directive 81, 154, 168

**A**

abstract classes 59–60  
action messages 84  
adopting protocols 102–103, 156  
+ `alloc` method 63, 128  
allocating instances 63, 128–131  
+ `allocFromZone:` method 128  
anonymous objects 99–100  
archiving 149–??  
arguments, variable number of 52, 70, 73

**B**

BOOL data type 152  
bycopy type qualifier 113–114, 123, 156, 167

**C**

C++, using with Objective C 48  
categories 94–97  
  declaration of 95, 155, 164  
  implementation of 95, 155, 164  
  uses of 96, 101–102  
Class data type 62, 152  
`@class` directive 71, 154, 164  
+ `class` method 62  
– `class` method 62  
class methods 62, 69  
class objects 55, 61–??, 67

classes 21–24, 55–78  
  declaration of 68–72, 155, 163  
  implementation of 72–78, 155, 164  
`_cmd` 85, 157  
`//` comment marker 153  
conforming to protocols 97, 104, 106–107  
– `conformsTo:` method 104, 106  
customizing  
  with class objects 63–65

**D**

`@defs()` directive 119, 154, 167  
designated initializer 135–138  
distributed objects 108–114  
dynamic binding 32–34, 53–54, 78–81  
dynamic loading 34–36, 146–??  
dynamic typing 31–32, 50–51

**E**

encapsulation 25–26  
`@encode()` directive 154, 168, 120–122  
`@end` directive 68, 154, 163, 164  
events 39

**F**

– `forward::` method 141–143  
forwarding 141–??  
– `free` method 140–141

**H**

hidden arguments *See self and \_cmd*

**I**

id data type 49–51, 60, 116, 152, 157, 166  
IMP data type 152  
implementation and interface 14–18, 43  
`@implementation` directive 72, 153, 155, 156, 164  
`#import` directive 70, 153  
in type qualifier 112–113, 123, 156, 167  
information hiding *See encapsulation*  
inheritance 27–30, 44, 55–60  
– `init` method 63, 131–138  
+ `initialize` method 66  
initializing  
  classes 66

instances 63, 131–140  
inout type qualifier 112–113, 123, 156, 167  
instance methods 62, 69  
instance variables 18, 48–49  
  declaration of 69, 155, 165  
  inheriting 57–58  
  of the receiver 52–53  
  outlets 36–38  
  referring to 73–78  
  scope of 75–78  
instances of a class 55  
  allocating 63, 128–131  
  initializing 63, 131–140  
interface and implementation 14–18, 43  
`@interface` directive 68, 153, 155, 163, 164  
introspection 50, 61  
isa instance variable 50–51, 79  
– `isKindOfClass:` method 61, 144  
– `isMemberOf:` method 61

**L**

late binding 34  
localization 147–148

**M**

message expressions 51, 152  
message receiver 20, 51, 152  
messages 19, 20–21, 51–52, 152  
messaging 53–54, 78–81  
– `methodFor:` method 118  
methods 18, 48–49  
  class methods 62, 69  
  declaration of 69–70, 157, 165  
  implementation of 73, 157, 165  
  inheriting 58–59  
  instance methods 62, 69  
  of the root class 66–??  
  overriding 29, 59  
  return and argument types 82, 117

**N**

naming conventions 158  
+ `new` method 138  
nil 50, 52, 153

---

NXBundle objects 146–??  
NXDefaultMallocZone() function 129

## O

objc\_lookUpClass() function 67  
objc\_msgSend() function 78  
Object class 55, 56–57  
objects 18–20, 48–49  
oneway type qualifier 110–111, 123, 156, 167  
out type qualifier 112–113, 123, 156, 167  
outlet instance variables 36–38  
overriding methods 29, 59

## P

–perform: method 82–83  
–perform:with: method 82–83  
–perform:with:with: method 82–83  
–performv:: method ??–143  
polymorphism 26–27, 43, 53  
@private directive 76–78, 154, 165  
@protected directive 76–78, 154, 165  
@protocol directive 102, 153, 156, 164  
Protocol objects 103–104  
@protocol() directive 104, 154, 156, 168  
protocols 97–107  
  adopting 102–103, 156  
  conforming to 97, 104, 106–107  
  declaration of 102–103, 156, 164  
  formal 102–107, 156–157  
  incorporating other protocols 106–107, 156  
  informal 101–102  
  type checking 105–106  
  uses of 98–101, 109  
proxy objects 108–114  
@public directive 76–78, 154, 165

## R

receiver of a message 20, 51, 152  
remote messages 107–114  
–respondsTo: method 84, 144  
reusability of software 23–24

## S

SEL data type 81, 152

sel\_getName() function 82  
sel\_getUid() function 81  
@selector() directive 81, 154, 168  
selectors 54, 81–82  
self 85–89, 90–91, 157, 167  
static typing 60–61, 66, 114–118  
subclasses 27, 29, 55  
super 86–90, 152, 157, 167  
superclass 27, 55  
surrogate objects 144

## T

target-action paradigm 83–84  
targets 84  
type checking  
  class types 116–117  
  protocol types 105–106

## Z

–zone method 130  
zones 129–131

